



# RF Basics

## Technology Guide



# Contents

## 1 Introduction

- Time vs. Frequency domain
- Superposition

## 2 The Electromagnetic Spectrum

## 3 Frequency Measurement Instrumentation

- The Oscilloscope
- Real-Time Spectrum Analyzers
- The Swept Superheterodyne Receiver
- Attenuator
- Preamplifier
- Preselection/Lo Pass Filter
- Mixer
- Local Oscillator (LO)
- The IF Filter
- The Analog-to-Digital Converter (ADC)
- Resolution Bandwidth (RBW) Filter
- The Details of a Sweep
- The Envelope Detector
- Video Bandwidth (VBW)
- Noise
- Sweep Speed
- The Vector Network Analyzer

## 4 Spectrum Monitoring with Real-time analysis

- Real Time Capture and Analysis
- Probability of Intercept
- Visualizations

## **5 Common Component Tests**

- The Tracking Generator
- Testing Filters
- Cable/Connector Loss
- VSWR of an Antenna

## **6 Common Transmitter Tests**

- Output Power
- Transmission Band
- AM Transmission Test
- FM Deviation
- Harmonics and Spurs

## **7 Common Receiver Tests**

- The Speaker (Optional)
- Audio Amplifier (Optional)
- Detector/Demodulator
- Selection and the IF Stages
- IF Amplification
- Local Oscillator (LO)
- Frequency Conversion/Mixer
- Selection/RF Stage
- Antennas, Cabling, and Adapters

## **8 Electromagnetic Interference (EMI)**

- Compliance vs. Pre-compliance
- Measuring Radiated EMI/Near-Field
- Near-Field Probing Setup
- Tips
- Measuring Conducted EMI
- Conducted Emission Measurement Setup
- Test Procedure
- Immunity Testing
- Radiated Susceptibility
- Additional Testing

## Chapter 1: Introduction

Radio frequency (RF) waves are fascinating natural phenomena that have allowed humanity to create tools to communicate over vast distances, observe other worlds, and gain a deeper understanding of our own planet. They are also ubiquitous here on Earth. We are surrounded by RF waves created by human technology, like the signals produced by radio and television stations and mobile phones, as well as signals emitted by natural sources like pulsars and supernovae scattered throughout the universe.

We created this document to explain the basics of RF signals, help you understand the time and frequency domains, and introduce common RF measurement instrumentation and measurement techniques. We hope you find this information helpful.

### Time vs. Frequency Domain

Events are often measured with respect to time. The average speed of a car, for example, can be calculated by dividing the distance traveled by the time it takes to travel that distance. Time domain measurements—those events measured with respect to time—are very useful to our understanding of the physical world and can be critical to building something that operates as intended.

In electronics, time domain measurements are extremely common. The point in time at which a certain event occurs can be key to the success or failure of a design. Unfortunately, humans don't have the ability to observe some elements of our world. Obviously, electrons are extremely useful, but they're notoriously small and hard to catch. However, we have been able to build tools that can help us observe electrons as they do their work. The oscilloscope is one of these tools. In fact, oscilloscopes are among the most common tools used to perform time domain measurements. In essence, an oscilloscope plots a graph of the voltage at its input with respect to time.

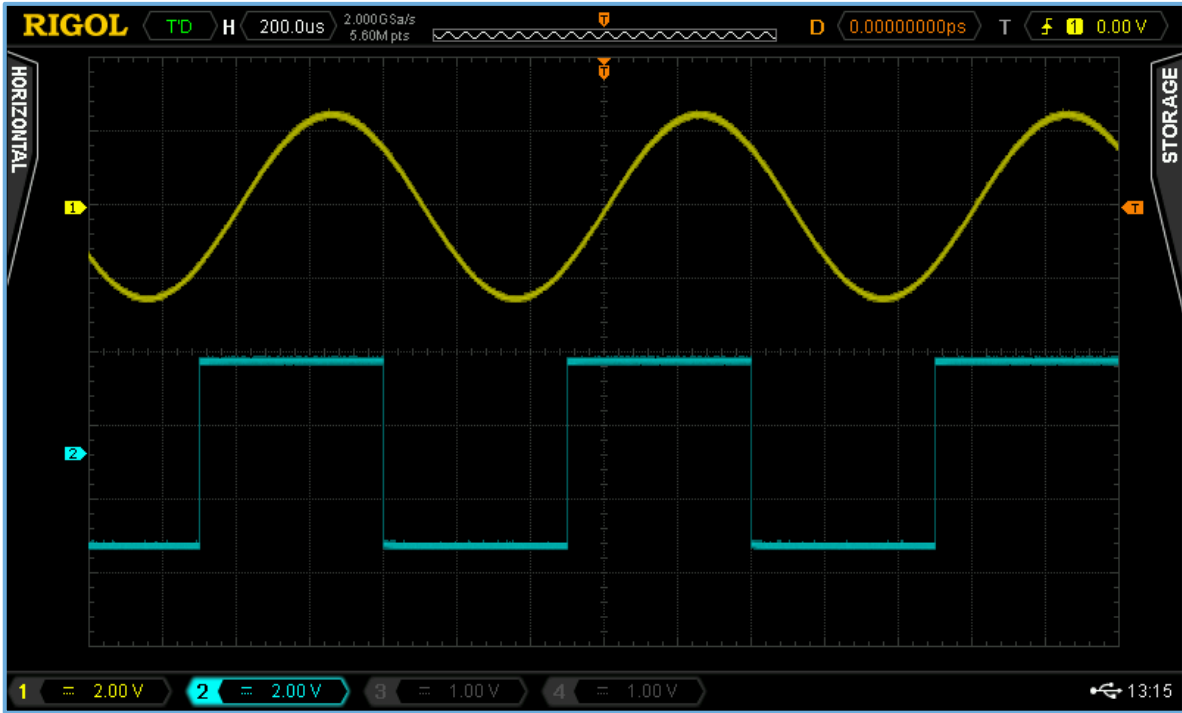

**Figure 1-1:** Oscilloscope display showing two waveforms. The display’s horizontal axis shows time; the vertical axis shows amplitude. The upper waveform is sinusoidal and the lower waveform is a square wave. Note that they contain elements that repeat with respect to time.

An oscilloscope can show when events occur, measure the amplitude of the event, and measure the time between events.

When discussing time-varying events, we often use terms from basic wave theory. Let’s take a look at a common wave function—the sine wave—and describe these basic elements in more detail.

The sinusoidal (sine) wave is a time-varying waveform with smooth transitions that occurs quite frequently in electronics.

The sine wave is mathematically represented by this equation:

$$y(t) = A \cdot \sin(2\pi f t + j)$$

Where  $y(t) = A$  is the amplitude,  $f$  is the frequency of oscillations (cycles) that occur per unit of time, and  $j$  is the phase, specifies (in radians) where in its cycle the oscillation is at  $t = 0$ .

The period of a time-varying signal is the smallest amount of time that defines a fundamental repeating element of the waveform. **Figure 1-2** shows a sinusoidal waveform illustrating the amplitude and one period of the waveform.

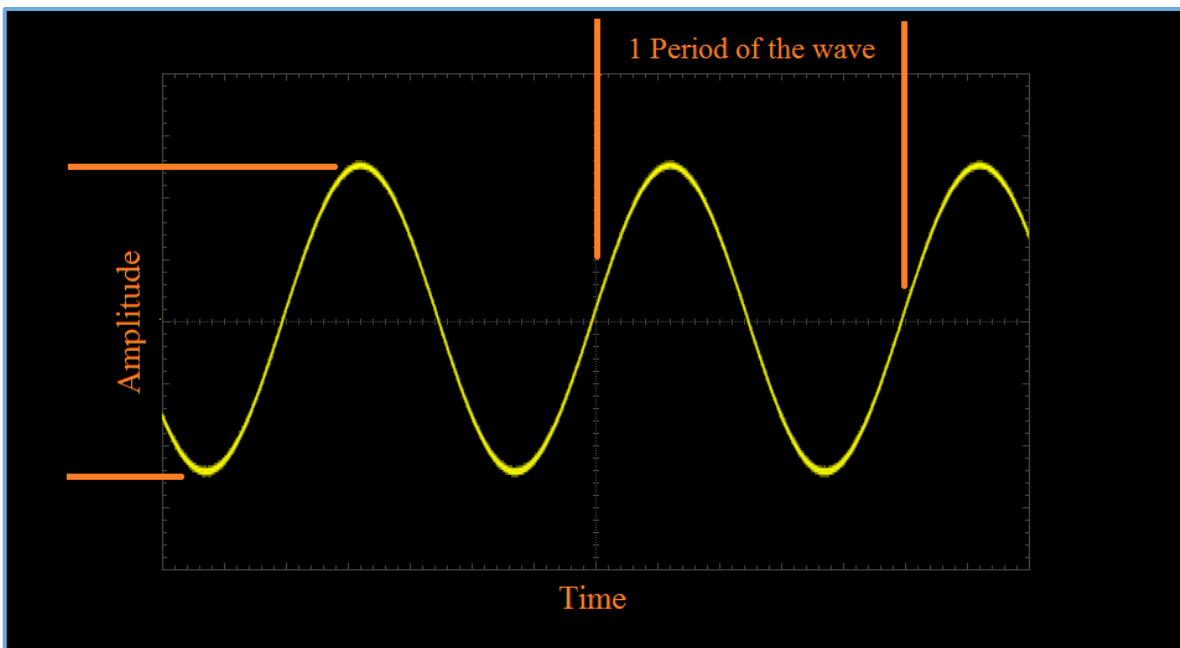

**Figure 1-2: Sinusoidal waveform with common waveform terminology.**

The frequency is the number of such periods that occur during a specific amount of time.

Time and frequency are linked by this equation:

$$f = 1/T$$

Where  $f$  is the frequency in Hertz (Hz) and  $T$  is the waveform period in seconds. Hertz is a secondary unit that represents the inverse of the waveform period (1/s).

Let's look at the voltage that comes from a wall outlet. In the United States, if we measured the voltage from a wall outlet with an oscilloscope, we would see that it has an amplitude of approximately 110V and a period of 16.67ms. That means that every 16.67ms, the voltage values repeat.

Now, what is the *frequency* of the voltage from a wall outlet in the United States?

$$f = 1/T = 1/16.67\text{ms} = 60\text{Hz}$$



As you can see, a waveform can be described by its characteristics in both the time and frequency domains.

### Superposition

Learning the basics of periodic waveforms like the sine wave offers extremely powerful tools for explaining and understanding more complicated waveforms.

**Figure 1-2** showed a single sine waveform. **Figure 1-3** illustrates what happens when we source a 5V sine wave into an oscilloscope:

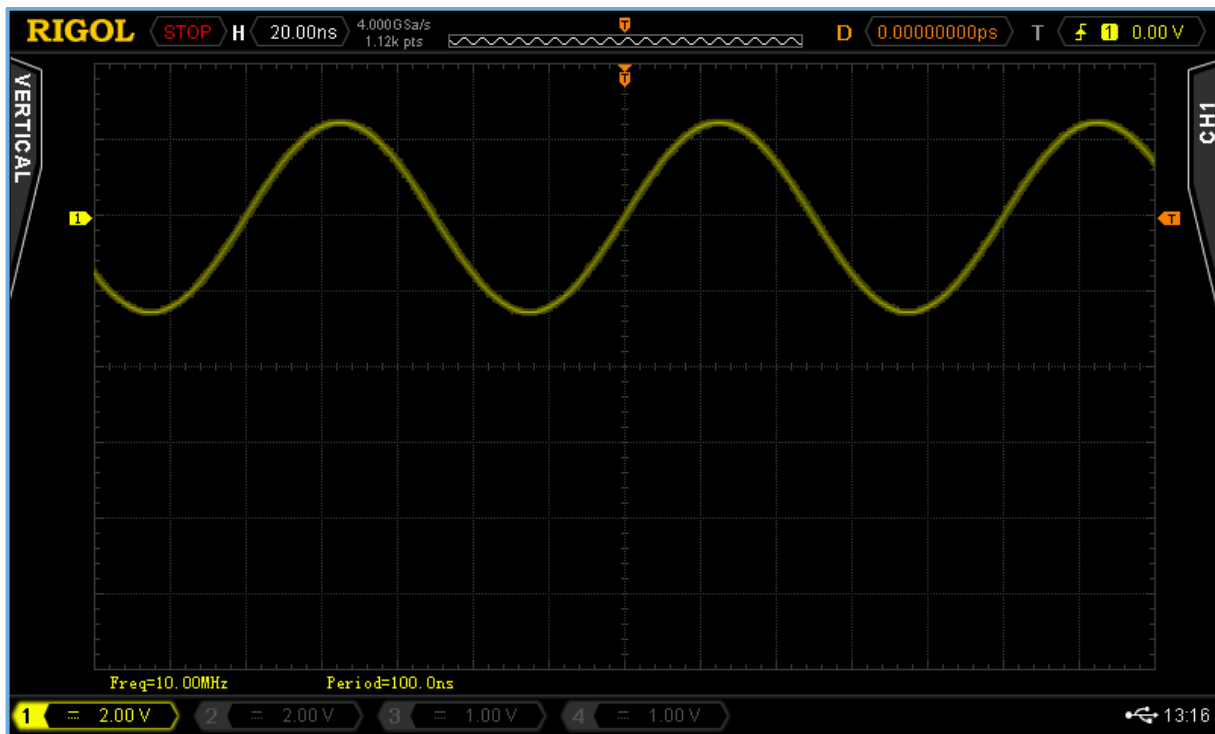

Figure 1-3: An oscilloscope displaying a sine wave with a frequency of 10MHz.

You can see that the frequency is 10MHz.

Now, let's source a 20MHz sine wave at the same time and compare the two (Figure 1-4).

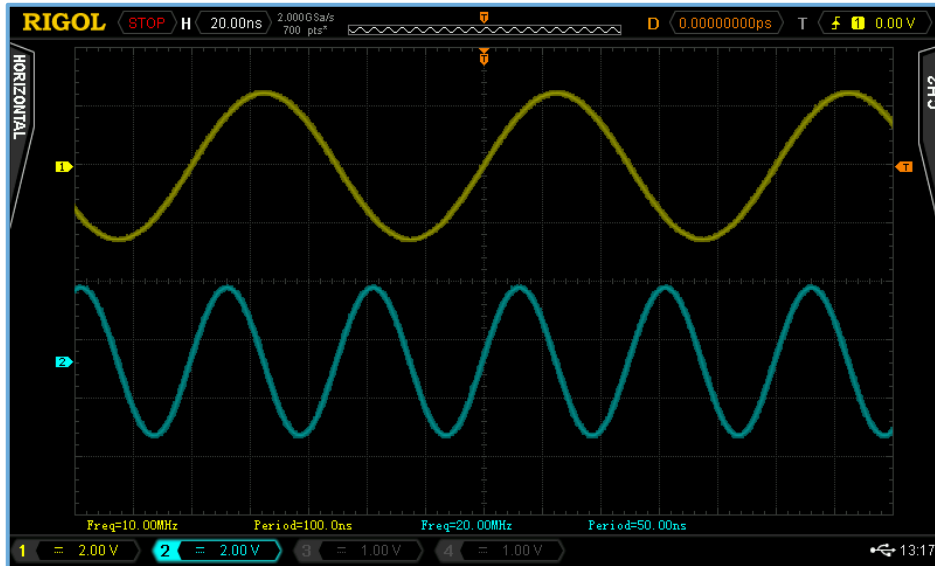

Figure 1-4: An oscilloscope display of one sine wave with a frequency of 10MHz (yellow) and another with a frequency of 20MHz (light blue).

So, we have a 10MHz sine wave and a 20MHz sine wave. What happens when we add these sine waves together? The waveform changes.



Figure 1-5: An oscilloscope displaying a sine wave with a frequency of 10MHz (yellow) and a wave that combines a 10MHz and a 20MHz sine wave (blue).



This is known as the superposition principle. You can add sine waves together and the resultant wave can have a drastically different shape than the original waveforms. To put it another way, any waveform can be constructed by the addition of simple sine waves.

Now, let's discuss some basic terms. The *fundamental frequency* of the new waveform is the lowest repeated frequency. In this case, the fundamental frequency of the waveform is 10MHz.

The *second harmonic* is a waveform with a frequency that is twice the fundamental. In this case, the second harmonic is 20MHz (2\*10MHz). You can continue on in this way to create any waveform.

Let's take a look at a special case. If you continue to add odd harmonics (1, 3, 5, 7, 9, etc.), you will build a square wave. The lower waveform in **Figure 1-6** was built using odd harmonics.

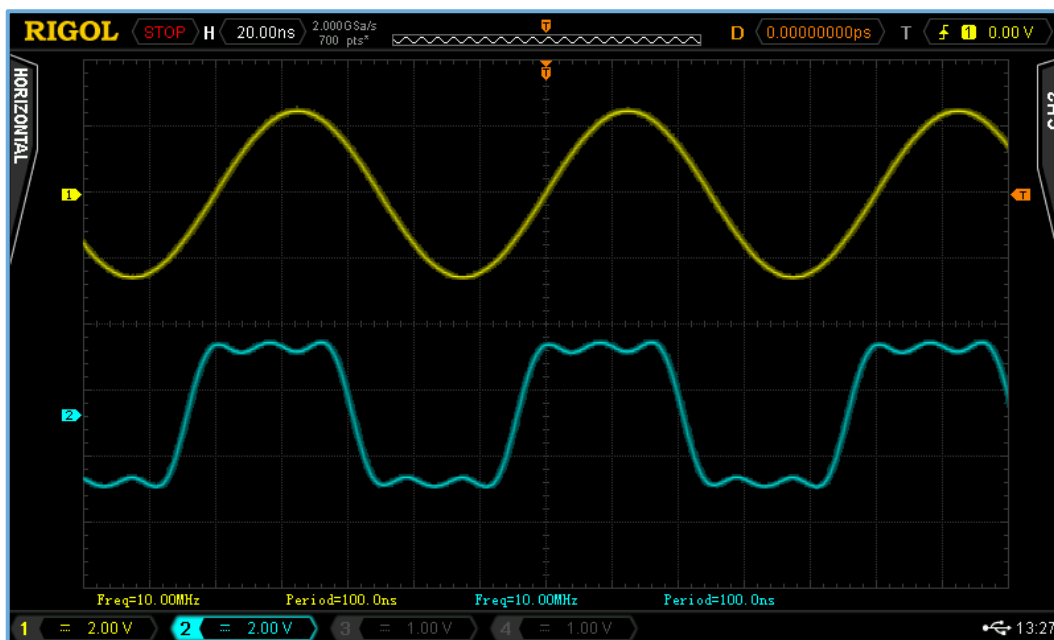

**Figure 1-6:** An oscilloscope display showing a sine wave with a frequency of 10MHz (yellow) and a square waveform with a frequency of 10MHz (light blue).

Note that the waveform is starting to look more “square,” but the frequency of the main shape is still at 10MHz.

What would these waveforms look like in the frequency domain?

A spectrum analyzer is an instrument that displays the amplitude vs. frequency for input signals.

If we source a 10MHz sine wave into a spectrum analyzer, the display looks like **Figure 1-7**.

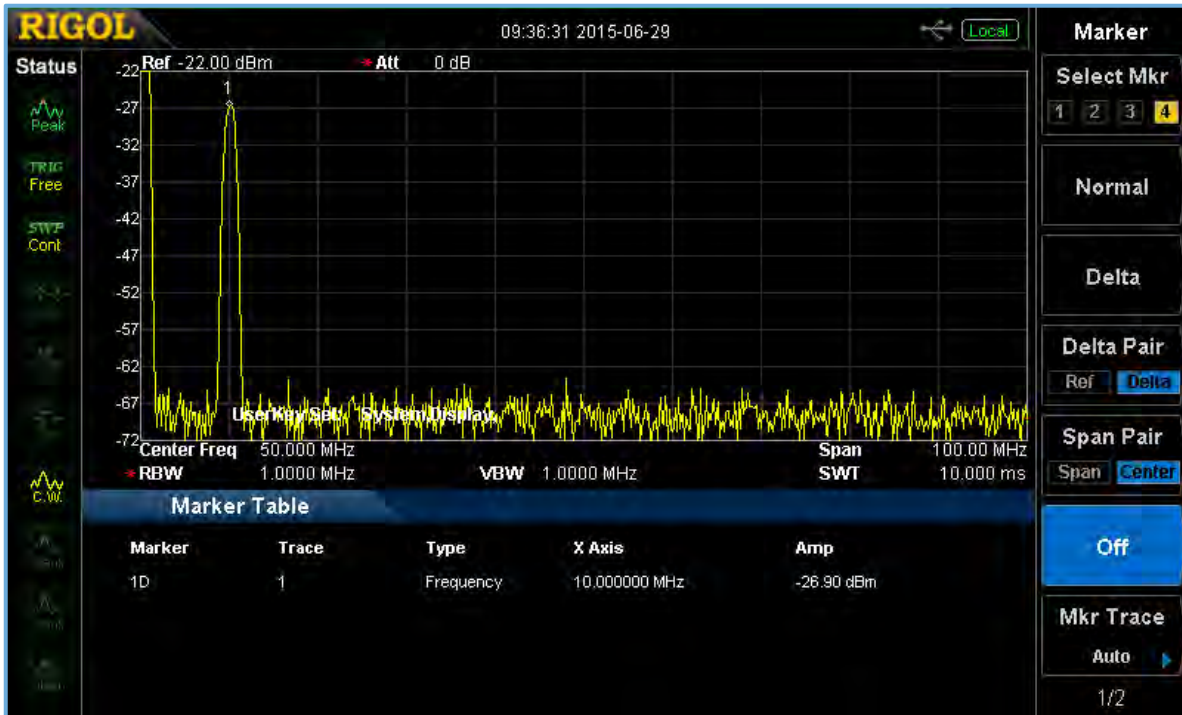

Figure 1-7: A 10MHz sine wave displayed on a spectrum analyzer. Note the peak at 10MHz.

Now, let's look at the square waveform on a spectrum analyzer (**Figure 1-8**).

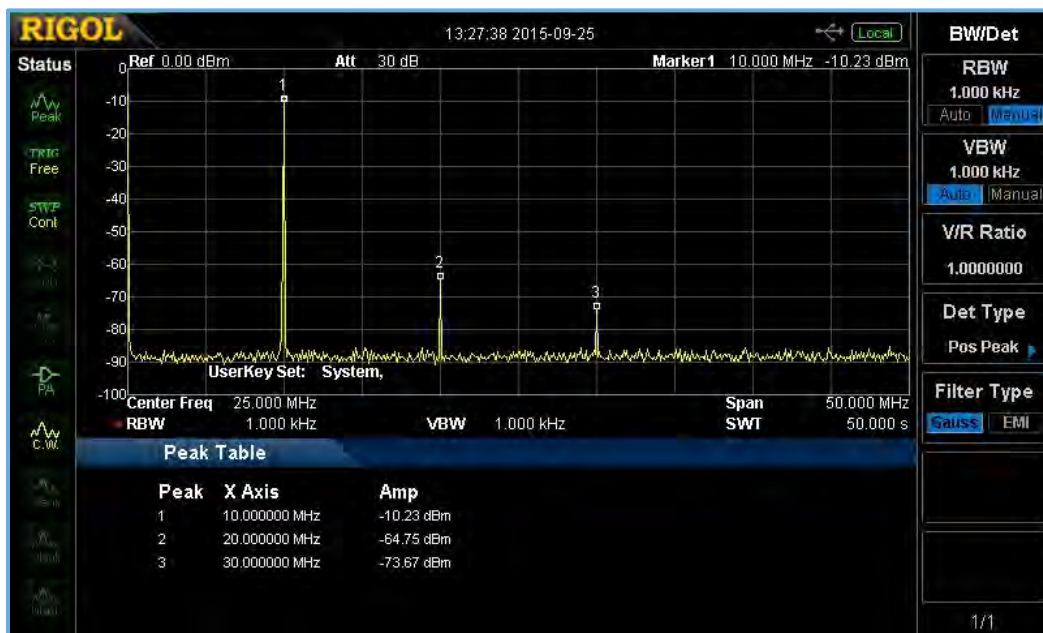

Figure 1-8: 10MHz square wave displayed on a spectrum analyzer.

You can see the fundamental frequency at 10MHz; the third ( $3 \times 10\text{MHz} = 30\text{MHz}$ ), fifth ( $5 \times 10\text{MHz} = 50\text{MHz}$ ), and seventh ( $7 \times 10\text{MHz} = 70\text{MHz}$ ) harmonics are also shown.

By visualizing the signal in frequency domain, it's easy to see what frequencies we are sourcing, as well as the power distribution for each frequency. Spectral analysis is critical in designing and troubleshooting communications circuits, radio/broadcast, transmitters/receivers, as well as Electromagnetic Compliance (EMC) measurements.

The following chapters will offer an overview of spectrum analyzer design and techniques for using these instruments properly.

Some of the most significant contributions to our understanding of waves come from a French mathematician, Jean-Baptiste Joseph Fourier (1768–1830). Fourier was investigating a solution to modeling the transfer of heat across a metal plate. As part of his work, he created a method of adding simple sine waves to create a more complicated waveform. His “Fourier Transform” has been used to solve many complex physical problems in thermodynamics and electronics. It also provides a way to convert signals captured in the time domain into the frequency domain. This concept has had far-reaching effects in electronics, communications, and the physical sciences. The superposition principle discussed earlier in this chapter is based on Fourier's initial research.

## Chapter 2: The Electromagnetic Spectrum

Now that we have introduced the time and frequency domains, let's take a closer look at electromagnetic radiation and the electromagnetic spectrum.

Electromagnetic radiation is a form of energy that is carried by synchronized oscillating electric and magnetic fields. It is unique in that its actions can be explained by theories that are based on both waves and particles. Electromagnetic radiation also travels without a medium. Waves on the ocean require water in order to exist; sound waves require air to propagate. Although neither of these waves can travel through a vacuum, electromagnetic waves can. In fact, they travel through the vacuum of space at the speed of light.

Recall that a wave can be described by its frequency of oscillation. Electromagnetic waves are no different and they cover quite a broad range of frequencies. In fact, nature has no known physical limits on maximum and minimum frequencies.

Frequencies are grouped into bands based on similarities in their physical traits or specific applications. Some frequency bands travel through the Earth's atmosphere with less loss; others are more useful for a particular application and are "set aside" for experimentation. Some bands have more than one official user.

Two common frequency bands to note are light and radio.

Visible light is defined as electromagnetic radiation with wavelengths from 400nm to 700nm (1nm is  $1 \times 10^{-9}$ m). This is equivalent to frequencies from  $5 \times 10^{14}$  Hz to  $1 \times 10^{15}$  Hz, although wavelengths are traditionally used when discussing light. Humans can see electromagnetic radiation with wavelengths (or frequencies) in this band.

The radio frequency (RF) band of electromagnetic waves has frequencies from 8.3kHz ( $10^4$  Hz) to 300GHz ( $10^{11}$  Hz).

Figure 2-1 illustrates the full electromagnetic spectrum and the RF band.

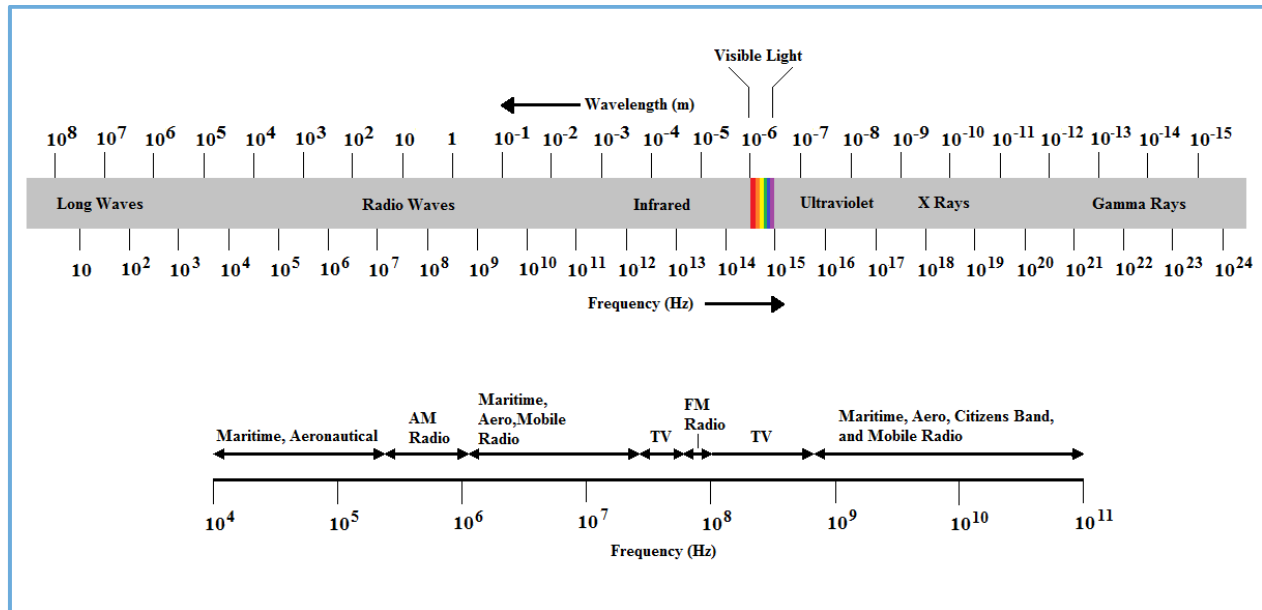

Figure 2-1: The full electromagnetic spectrum and the RF band.

The RF band is useful for many industries and applications, including direct audio communications (mobile phones, mobile radios, FM radios), device communications (wireless keyboards, Wi-Fi hotspots, game controllers), and interplanetary research (like the giant radio telescope at the Arecibo Observatory in Puerto Rico).

Within the RF band, specific frequencies are dedicated to communication and broadcast that are open to anyone with the ability to transmit. The Citizens Band (CB) as well as Industrial, Science, and Medical band (ISM) are examples of unlicensed communications bands.

Others, like FM radio, are licensed channels that are specifically allocated or rented by individuals or corporations for a particular use. The national government and the channel licensee monitor licensed broadcast channels very closely in order to ensure that the broadcasts adhere to certain content and physical transmission criteria. In the United States, the Federal Communications Commission (FCC) regulates the RF spectrum.

Electromagnetic interference (EMI) is another important aspect of the RF story. Devices designed to transmit and receive RF signals are classified as intentional radiators. Examples include FM radios, Wi-Fi

routers, and wireless keyboards. However, other devices that are not specifically intended to create RF signals are classified as unintentional radiators; they represent the primary source of EMI.

EMI is RF noise. An unintentional radiator creates RF radiation that is not intended to communicate, control, or deliver any relevant information. Therefore, unintentional radiators are RF noise sources. Some designs exhibit less noise than others. But, just imagine if every electronic device emitted a large amount of RF noise! What if your radio-controlled car interfered with the radar at a nearby airport?

In order to control and maintain a safe operating environment, governments regulate the amount of acceptable EMI that a design or product can produce. Products that exceed the limits set forth by the regulations can lead to heavy financial penalties for offending individuals or companies.

When performing experiments and development with RF, it is very important to understand the requirements of working within a specific frequency band. If you are working within a licensed or restricted band, make sure to research how to do that safely and work within the regulations for that band.

Our previous discussions on the time/frequency domains and the electromagnetic spectrum have provided a base for our knowledge of RF. In the following sections, we will introduce basic RF measurement instrumentation and techniques, with a focus on typical RF component tests, broadcast/radio monitoring, and EMI.

### Chapter 3: Frequency Measurement Instrumentation

Chapters 1 and 2 offered details about waves, frequency, RF, and the electromagnetic spectrum. Chapter 3 highlights common instrumentation used to measure signals in the time and frequency domains, and delves deeper into the inner workings of spectrum analyzers.

#### The Oscilloscope

In many cases, looking at a signal in the time domain can provide indications about the performance of a particular design. It can tell you how quickly a signal achieves its maximum voltage (rise time) or its lowest (fall time), how two signals compare with one another vs. time, or the duration of a signal. All of these measurements are ideally measured in the time domain.

The oscilloscope, introduced in chapter 1, measures voltage with respect to time, then displays the graph of voltage (amplitude) vs. time (**Figure 3-1**).

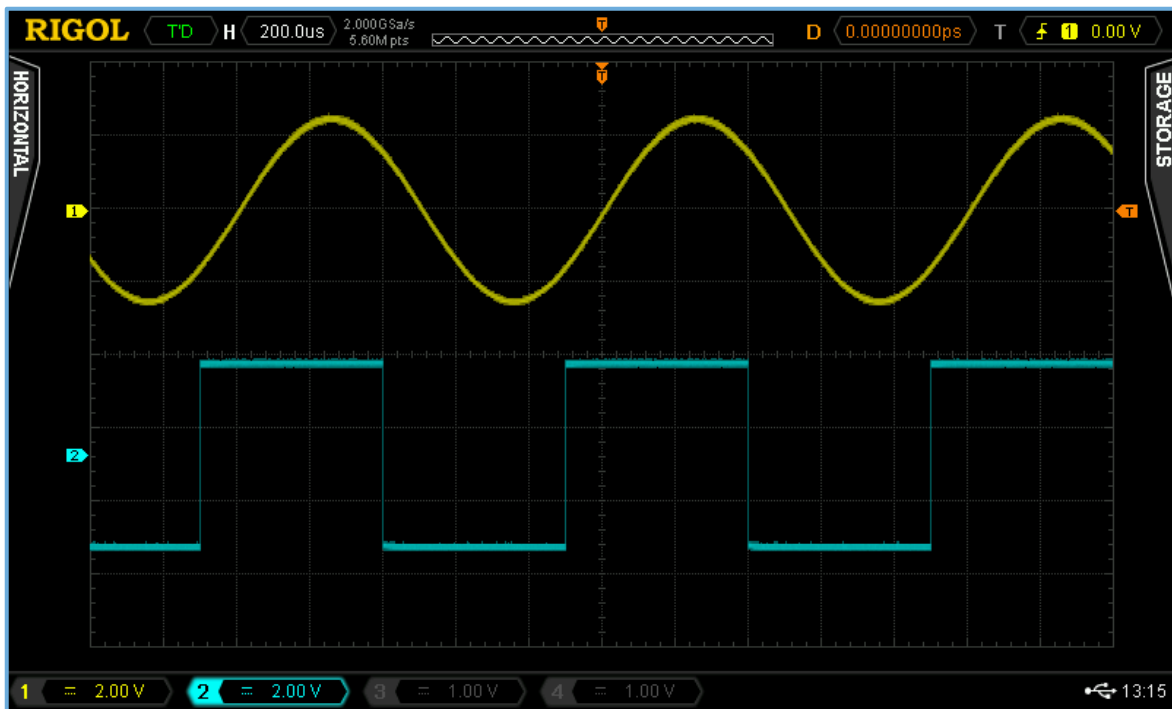

Figure 3-1: Oscilloscope display showing two waveforms. The horizontal axis of the display shows time; the vertical axis displays amplitude. The upper waveform is sinusoidal and the lower waveform is a square wave. Note that they contain elements that repeat over time.



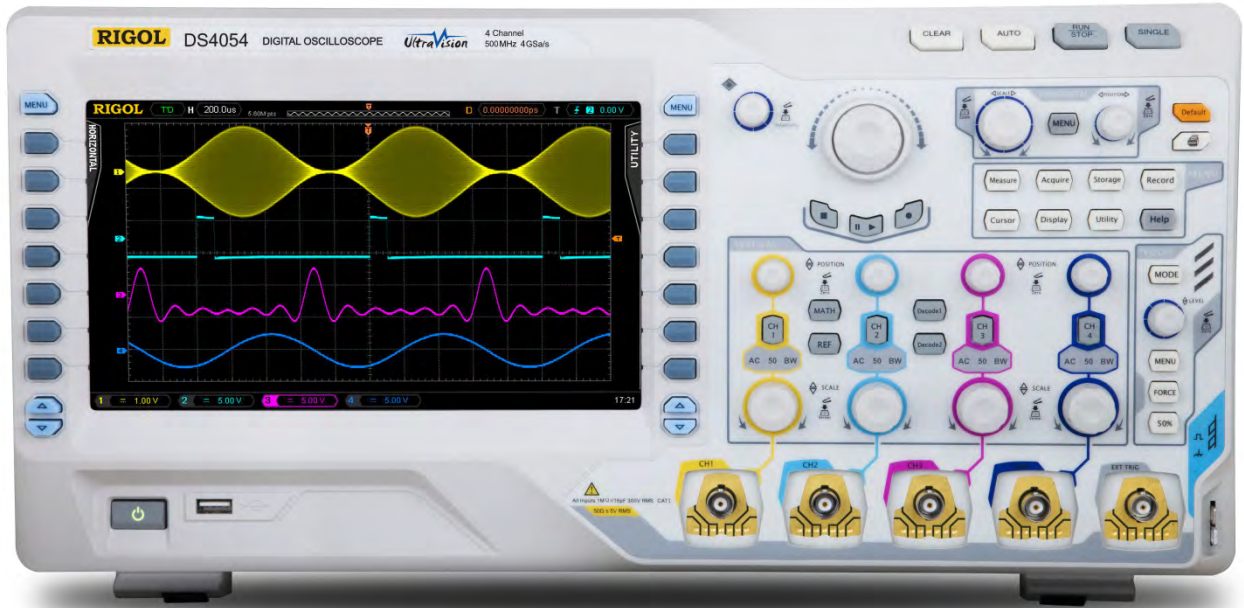

Figure 3-2: A modern digital oscilloscope.

Early oscilloscopes were strictly analog in nature and used a cathode ray tube (CRT) as a display. Much like an analog television set, these scopes would “draw” the incoming signal on the display. This was extremely helpful in visualizing the input signal but made it difficult to perform any direct measurements; the only way to save data was to take a picture of the display of the oscilloscope.

The advancement of digital technology led to fully digital oscilloscopes (**Figure 3-2**). With the raw voltage and time data digitized, the data could be saved and used to perform calculations directly within the scope itself. Modern oscilloscopes can now directly calculate rise time, duty cycle, maximum voltage, and more.

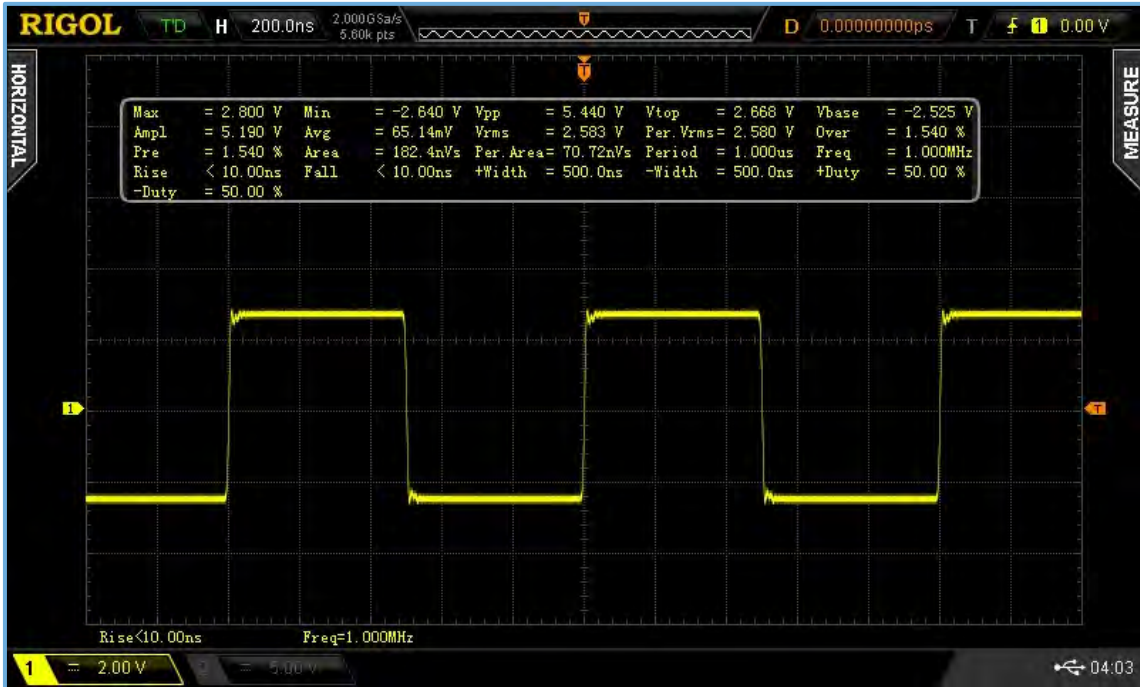

Figure 3-3: Oscilloscope display showing all measurements for a 1MHz square wave input.

Some digital scopes can also display the amplitude of the incoming signal vs. frequency by using Fast Fourier Transform (FFT) calculations. The FFT function of oscilloscopes can be useful in identifying the fundamental frequency, as shown in Figure 3-4.

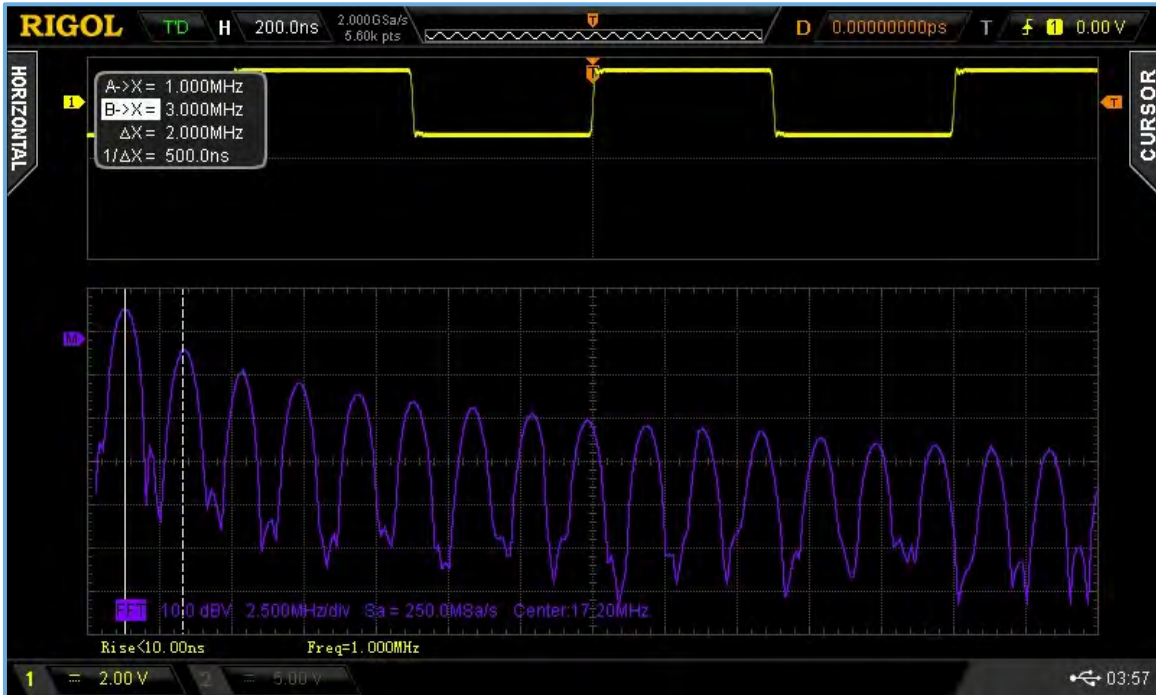

Figure 3-4: Oscilloscope display showing an FFT of a 1MHz square wave input.

So, with a scope, we can read the phase information (in the time domain) and gather basic amplitude and frequency information in the frequency domain by using FFTs. Unfortunately, oscilloscopes tend to have a much higher noise floor than traditional frequency measurement instrumentation like spectrum analyzers. This can make looking for small amplitude elements, like higher ordered harmonics, difficult if not impossible. They are also “wideband” instruments, which means that they detect a wide range of frequencies at the same time. This raises the noise floor and does not provide for an easy way to differentiate between signals that could have frequencies that are close together.

### Real-Time Spectrum Analyzers

Real-time spectrum analyzers are similar to oscilloscopes in that they first collect data in the time domain, then calculate the frequency using FFT algorithms. In this way, they can collect a large number of data points over a broad range of frequencies, calculate the amplitude vs. frequency, and display them quickly in the frequency domain. They differ from oscilloscopes in that they tend to offer lower noise floors, as well as special filtering that can differentiate between signals that are close together.

Real-time spectrum analyzers are very useful in capturing fast-changing signals, especially when working with digital communications. They generally can capture transients and fast signals more quickly than a swept spectrum analyzer, but they also have a higher noise floor and price tag.

Although real-time systems are gaining in popularity, they are still significantly outnumbered by the swept analyzer design. The remainder of this section will explore the inner workings of the most popular method of frequency measurement, the swept spectrum analyzer.

### The Swept Superheterodyne Receiver

Spectrum analyzers based on swept superheterodyne designs are very popular, due in part to their low noise, ease of use, and ability to differentiate between signals that have very close frequencies.

In basic terms, the swept superheterodyne is almost identical to a radio receiver. Both can be set to a particular frequency range and filter out other frequencies (like tuning to particular radio station) and then observe the incoming signal. Unlike a radio, which is tuned to a particular frequency and then the signal is fed

to a speaker, an analyzer is not set to a fixed frequency. Instead, the analyzer sweeps across frequencies in steps, like moving the radio to a new channel, and then plots the signal amplitude on a display.

In simple terms, this design takes an unknown signal (an input or  $RF_{IN}$  signal) and mixes (combines) it with a sweeping signal, or swept Local Oscillator (LO), to create a signal that is a combination of both. The LO is swept from a start frequency to a stop frequency in discrete steps. Each step in the sweep defines a frequency “bin” on the spectrum analyzer display. At each bin, the power is measured. If the unknown signal has a frequency component within the bin, the display will place a data point at the equivalent amplitude of the unknown signal. After the sweep is completed, the resulting display will represent one scan across the span defined by the start and stop values of the instrument. The following sections will examine how each circuit element is used to create this output.

First, let’s look back at a little electrical engineering history. The term *superheterodyne* is short for *supersonic heterodyne*. The basic design was created by Edwin Armstrong, an American electrical engineer, in 1918. *Supersonic* refers to waves with frequencies higher than those within the range of human hearing (31Hz to 21kHz). *Heterodyne* is a contraction of the Greek words *hetero-*, which means “different” and *-dyne*, which means “power.”

**Figure 3-5** illustrates a basic design for a modern superheterodyne receiver used in a spectrum analyzer.

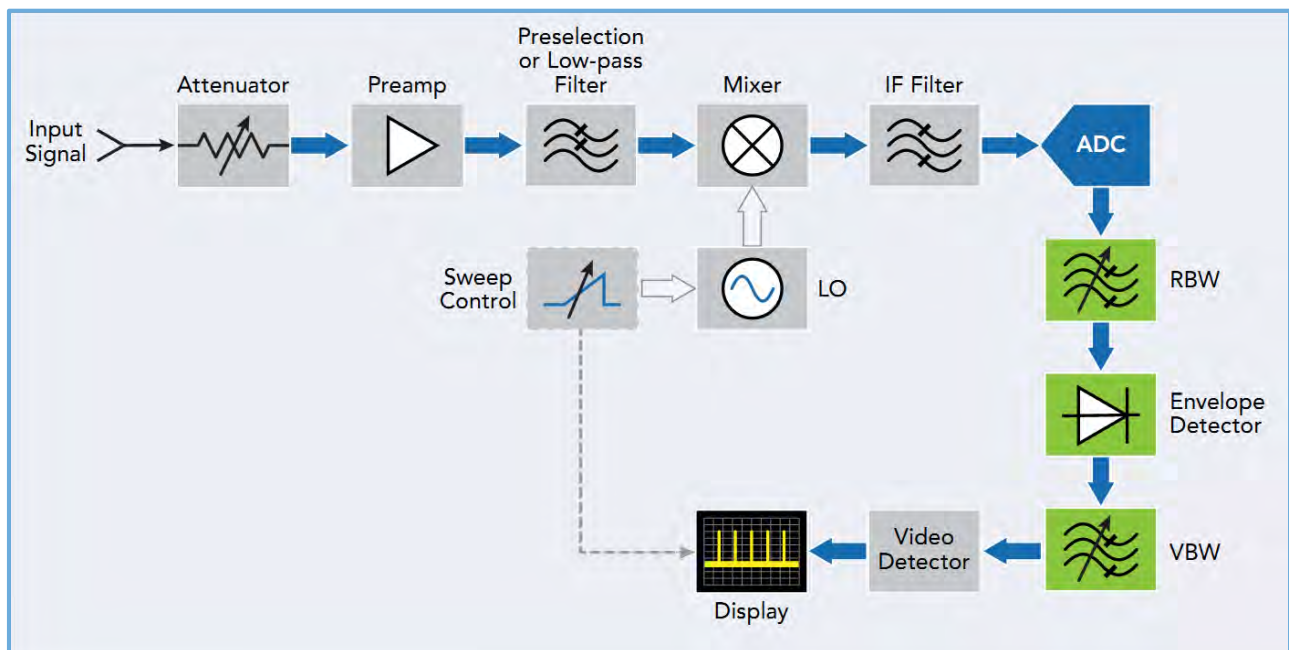

**Figure 3-5:** A modern superheterodyne receiver used in a spectrum analyzer.



Let's take a look at each of the elements as a signal passes through each of them.

### Attenuator

The input RF signal is connected to the spectrum analyzer's RF input where it enters the attenuator circuit. The attenuator is used to decrease the amount of power delivered to the circuit elements that follow it. This protects the sensitive electronics that follow and decreases the effects of spurs and modulation effects in the mixer. In many cases, a design can incorporate an integrated attenuator that can be controlled by settings on the analyzer. External attenuators that have fixed or variable attenuation can also be used.

### Preamplifier

The preamplifier (PA) is a low noise amplifier that increases the input signal amplitude (**Figure 3-6**). It can increase the signal-to-noise ratio and helps increase the measurement sensitivity to low power elements in the input signal. It is also usually controlled by the spectrum analyzer.

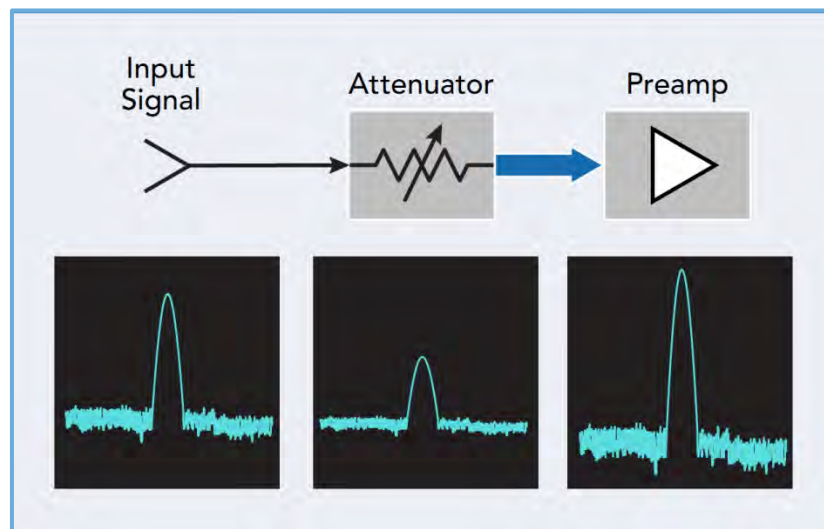

Figure 3-6: The effect of an attenuator and a preamplifier on an input signal.

### Preselection/Lo Pass Filter

The preselection filter is a bandpass filter that only allows certain frequencies to reach circuit elements. Unwanted signals are rejected to prevent them from causing measurement errors. Preselection filters may or

may not be included in a particular design. Although they add complexity and cost, they do reduce the likelihood of false peaks in the scanned spectra.

A low-pass filter typically prevents frequencies that exceed the maximum operating frequency from entering the circuit. This stops them from entering the next stage of the circuit, where they could be more difficult to remove. A DC block is also included in the RF input circuit. This element blocks out any DC components of the input that can cause overloading or damage to the remaining circuit elements.

### Mixer

A mixer is a three-port circuit element that takes two input signals and creates an output signal that is a combination of both the  $f_{RF_{IN}}$  and  $f_{LO}$ . In this design, the mixer multiplies the unknown input signal (frequency =  $f_{sig}$ ) with the known local oscillator (frequency =  $f_{LO}$ ).

The resultant output (**Figure 3-7**) is composed of the original RF signal ( $f_{sig}$ ), the local oscillator signal ( $f_{LO}$ ), and both the sum and difference of the RF and LO inputs ( $f_{LO} - f_{sig}$  and  $f_{LO} + f_{sig}$ , respectively), and the sum and difference of higher harmonics, such as  $(2f_{LO} - f_{sig}/2f_{sig} - f_{LO}$  and  $2f_{LO} + f_{sig}/2f_{sig} + f_{LO})$ .

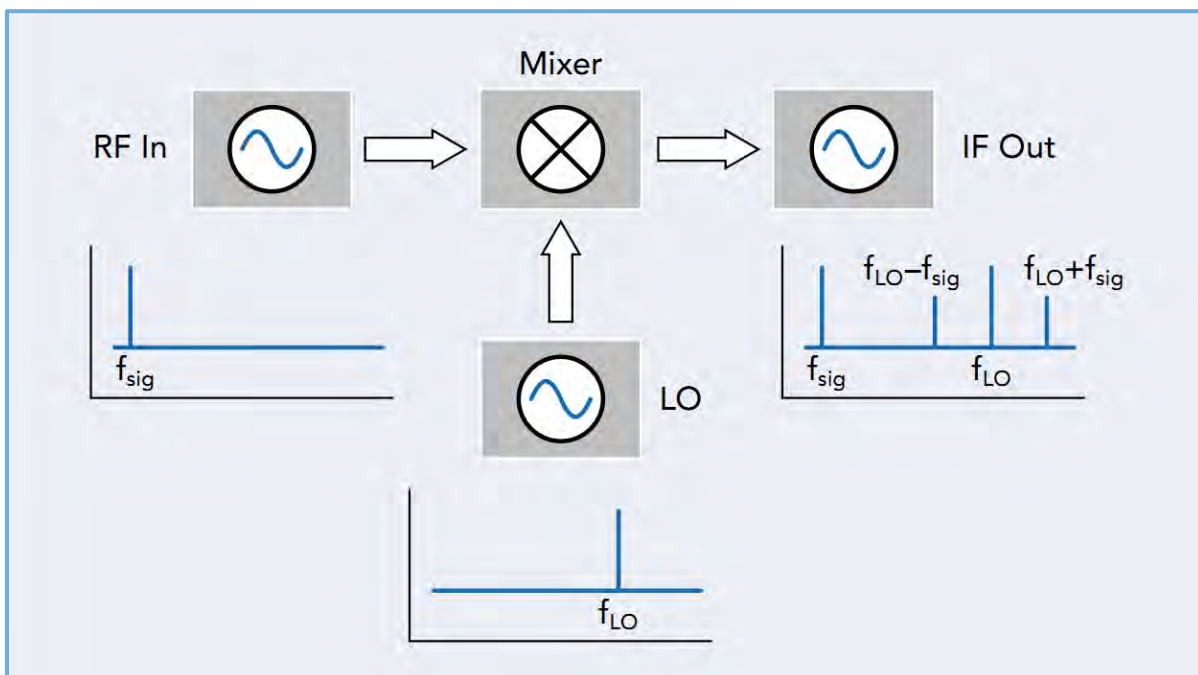

**Figure 3-7:** The input signal ( $f_{sig}$ ) is mixed with the local oscillator signal ( $f_{LO}$ ). The result is the  $IF_{out}$ , which includes the fundamental mixed products.

The output frequency from the mixer is known as the intermediate frequency (IF).

The  $IF_{out}$  components that include only the difference between the LO and the input frequencies ( $f_{LO} - f_{sig}$ ) are known as the downconverted signal.

The  $IF_{out}$  components that include only the sum between the LO and the input frequencies ( $f_{LO} + f_{sig}$ ) are known as the upconverted signal.

Let's consider an example:

If  $RF_{IN}$  is 100MHz and LO is 2GHz, what are the values of the downconverted and upconverted IF outputs?

Downconverted signals are calculated by subtracting the  $f_{sig}$  components from the intermediate frequency as shown here:

$$\begin{aligned}IF_{(down)} &= f_{LO} - f_{sig} \\f_{LO} &= 2\text{GHz} = 2\text{E}+9 \text{ Hz} \\f_{sig} &= 10\text{MHz} = 10\text{E}+6 \text{ Hz} \\IF_{(down)} &= (2\text{E}+9 \text{ Hz}) - (10\text{E}+6 \text{ Hz}) = 1.99\text{E}+9 \text{ Hz} = 1.99\text{GHz}\end{aligned}$$

and,

$$\begin{aligned}IF_{(up)} &= f_{LO} + f_{sig} \\IF_{(up)} &= (2\text{E}+9 \text{ Hz}) + (10\text{E}+6 \text{ Hz}) = 2.01\text{E}+9 \text{ Hz} = 2.01\text{GHz}\end{aligned}$$

In reality, multiple mixer stages can be used in series to provide the right balance of resolution and operational frequency range. Narrow bandwidth filters are needed to provide fine frequency resolution, but we want the filter to operate over a large range of frequencies. These two requirements often seem to be at odds because narrow bandpass filters are not effective over large frequency ranges and adding filters increases the cost and complexity of a design.

By adding multiple IF stages, it's possible to maximize the frequency resolution and extend the operating range. Multistage IF sections can upconvert (step up) or downconvert (step down) the  $f_{LO}$  to a different range, where they can be filtered to remove unwanted frequencies at each step as shown in **Figure 3-8**.



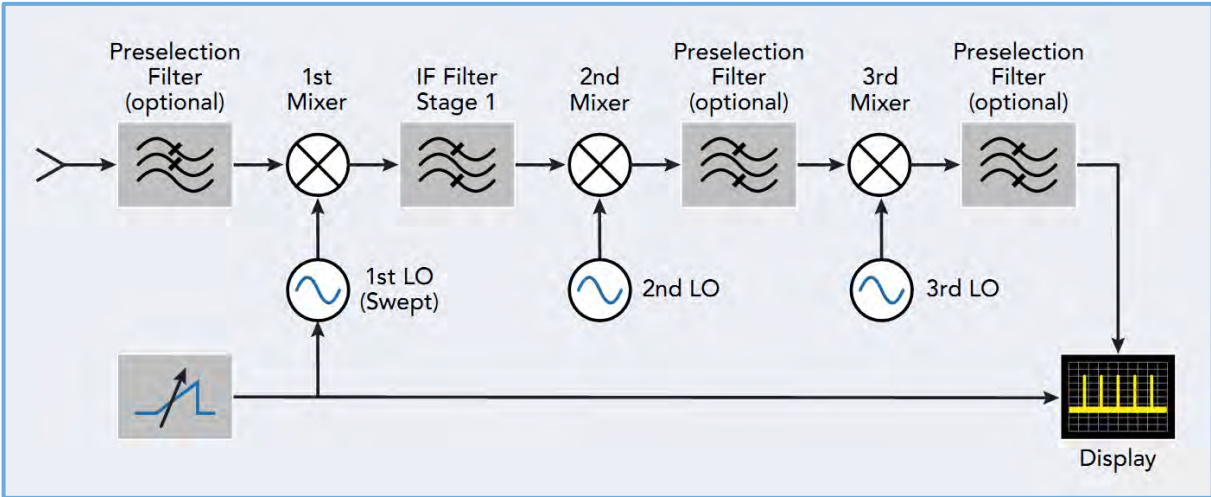

Figure 3-8: A diagram of a triple conversion IF stage.

The use of multiple mixing stages allows the instrument to have superior sensitivity, good frequency stability, and high frequency selectivity. This allows the instrument to have a wide operating frequency range and the ability to differentiate signals that have frequencies that are close together.

**Local Oscillator (LO)**

Local oscillators (LOs) are an integral part of the mixer network. An LO is a circuit element that provides a signal at a known frequency and amplitude. An LO can be made up of different designs and materials, but its main purpose is to provide a stable frequency reference that can be used to compare unknown RF from the input stages.

Many designs (**Figure 3-9**) incorporate a swept LO as the first stage (1st LO). A swept LO uses a Voltage Controlled Oscillator (VCO). As the voltage to a VCO is increased, the output frequency also increases.

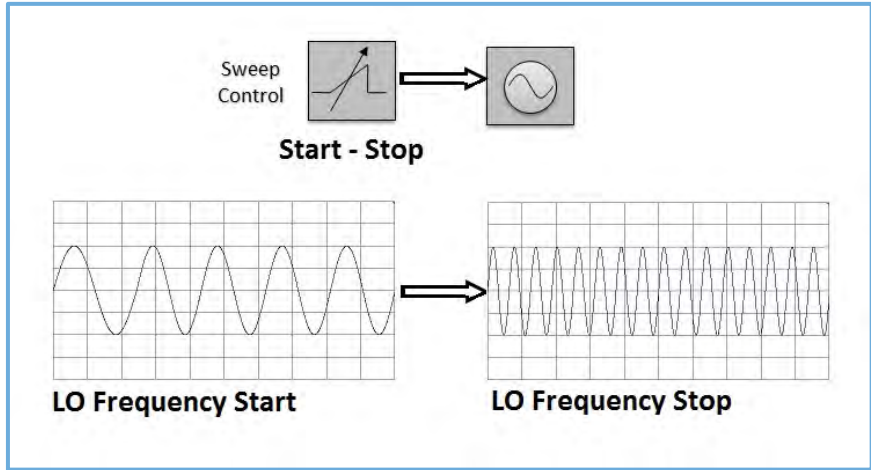

Figure 3-9: Example of a swept Voltage Controlled Oscillator (VCO)

The sweep function is also tied to the instrument display. As the LO steps from the start to the stop frequency, the frequency step, or “bin” of the display is also stepped. This synchronization ensures that the IF and the displayed values for each frequency “bin” are matched.

The local oscillator frequency is based on a reference oscillator within the circuit. This reference oscillator is generally a crystal oscillator, like quartz, that vibrates at a known frequency. A perfect reference oscillator would have an infinitely accurate output frequency that would not change with aging or temperature. It would have no “spectral width” and would be a straight line at the oscillator frequency, as shown in **Figure 3-10**.

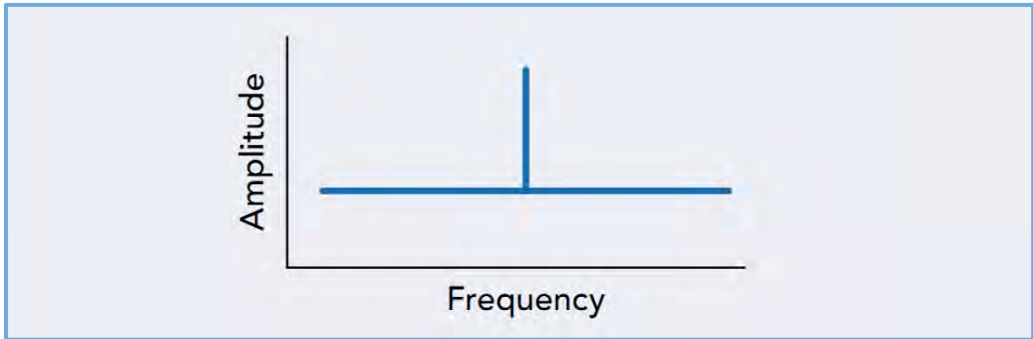
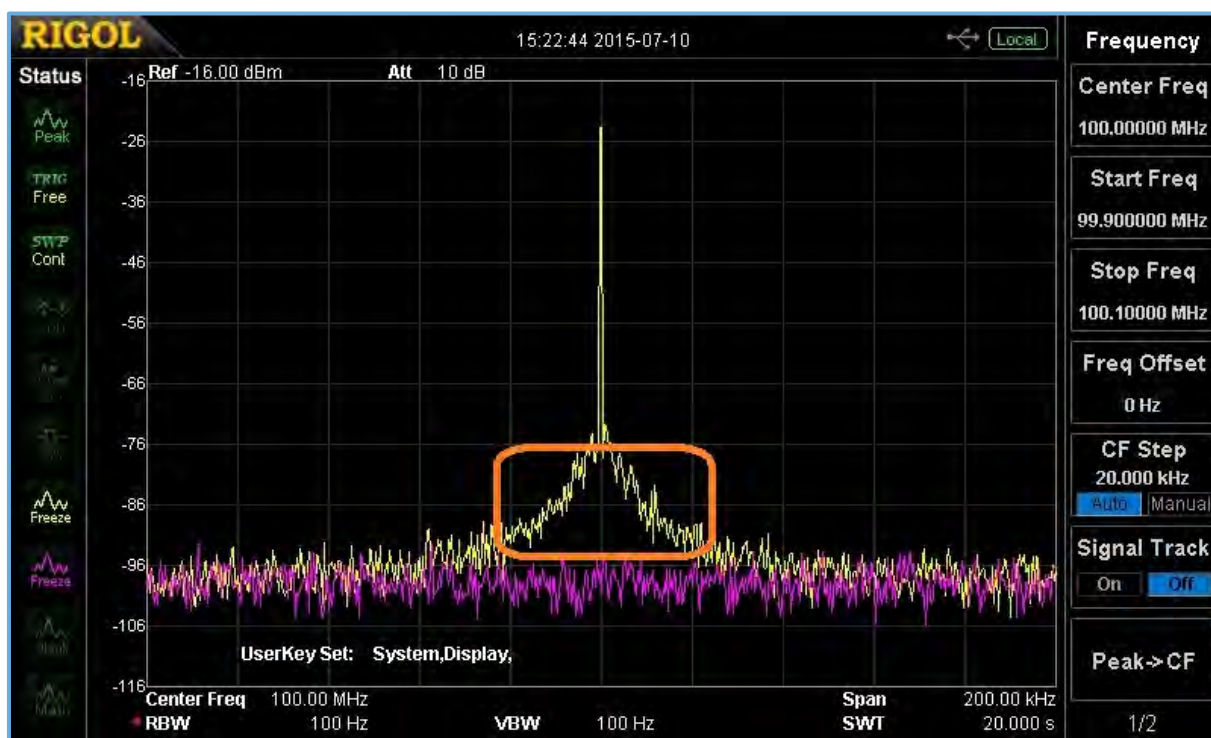

Figure 3-10: Example of a perfect oscillator output. Note there is only one single frequency with no width.

Unfortunately, the vibrations (and therefore the output frequency) for oscillators are effected by environmental conditions like aging, temperature, and humidity. This leads to phase noise.

Phase noise represents the change in the phase of an oscillators output signal over time. On a spectrum analyzer, phase noise shows up as a widening of the occupied frequencies of an input. This widening can be described as a wedge or “skirt” near the bottom of measurement as highlighted in the box in **Figure 3-11**.



**Figure 3-11:** A real oscillator measurement showing the phase noise that is due to thermal fluctuations in the circuit elements.

Phase noise effectively increases the noise floor and can increase the difficulty of observing small signals close to an input frequency by effectively covering the signals that you are seeking. Low phase noise can help increase the low-level signal observation near measured input frequencies.

The yellow trace in **Figure 3-11** is a 100MHz RF input. The purple line is the noise floor of the analyzer with identical measurement settings. Note the rise in the noise floor approaching the center frequency of the 100MHz input. This phase noise is coming from either the source or the analyzer, whichever is greater.

Phase noise can be minimized by selecting quality reference oscillator materials as well as environmental control.

Temperature Compensated Crystal Oscillators (TCXO), Microcontrolled Crystal Oscillators (MCXO), and Oven Controlled Crystal Oscillators (OCXO) are some common designs that can be incorporated to help limit the phase noise of a particular design.

### The IF Filter

The IF filter follows immediately after the mixer. It filters out the  $f_{sig}$ ,  $f_{LO}$ , and leaves either the upconverted ( $f_{LO} + f_{sig}$ ) or downconverted signal ( $f_{LO} - f_{sig}$ ), as shown in **Figure 3-12**.

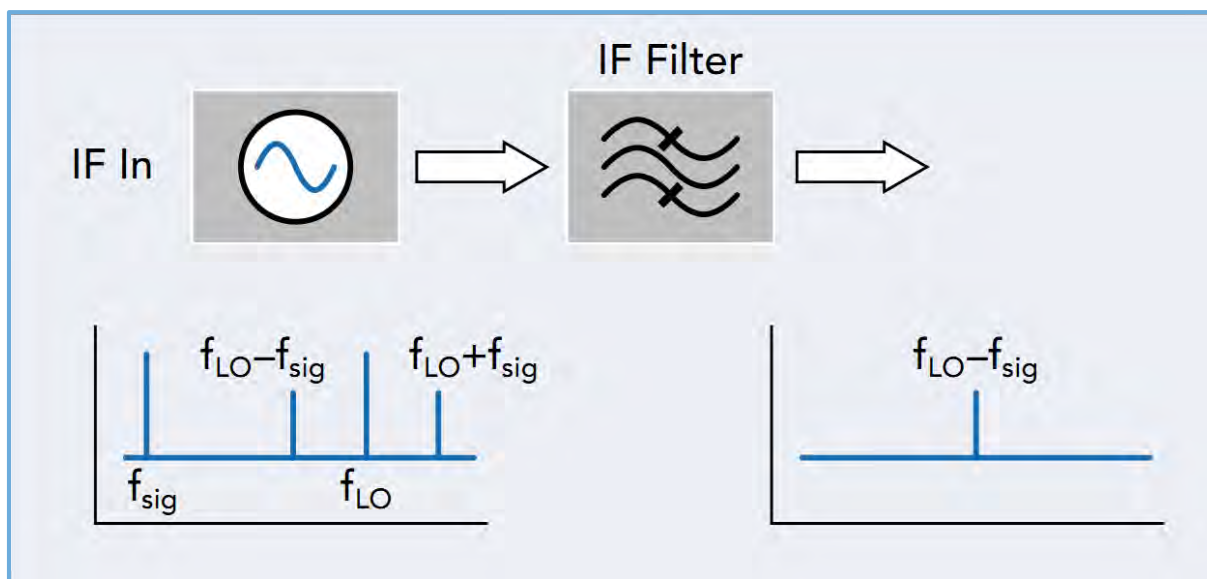

**Figure 3-12:** Output of the IF stage after the IF filter.

Now, a known signal ( $f_{LO}$ ) has been subtracted from the original signal of an unknown frequency to create the IF. Because we know the frequency of the  $f_{LO}$ , we could apply a filter with a known center frequency and known bandwidth to the IF and measure the output. If the IF does not exist in that frequency range, we could step to another filter (with a different center frequency) and check again. With enough filters, we could continue to step through center frequencies and look for the IF. Once we find the center frequency of the IF, we can subtract the original  $f_{LO}$  and the result would be our previously unknown  $f_{sig}$ .

In practice, designing analog filter networks with enough range and performance to cover giga-hertz of frequency ranges can be difficult and expensive. In the past, fully analog designs were the only available

option. They worked very well over their intended ranges, but there are disadvantages to a fully analog system.

Most modern designs incorporate a different strategy to isolate the unknown signal. They use a final IF stage with a fixed center frequency and the LO is swept. The next section covers how this swept design eases the design burdens and increases functionality of spectrum analyzer design.

### The Analog-to-Digital Converter (ADC)

The first few generations of spectrum analyzers used analog components throughout their design, with the readout being an analog cathode ray tube (CRT) display. Wider operating ranges and smaller bandpass filters required more components. Due to the nature of the available analog components, a fully analog spectrum analyzer was substantial in size, weight, and cost.

Some older spectrum analyzers could be as large as 24" × 24" × 24" in size, weigh over 40 pounds, and cost more than \$40,000. Today, many of the filters and other components have been replaced by digital signal processors (DSPs), which can successfully model the characteristics of their analog counterparts. The integration of digital components has simplified the design and decreased the size, weight, and cost. A modern spectrum analyzer a bit bigger than a shoebox and weighing less than 10 pounds can be purchased for less than \$10,000. There are even USB-controlled instruments that are as small as a pack of playing cards for a few hundred dollars.

Now, back to our original discussion. The unknown signal has been converted to create the IF (intermediate frequency). The IF signal is then sent to an analog-to-digital converter (ADC). The ADC creates a digital output that is proportional to the analog input.

Once the signal has been converted to a digital signal, it can be easily manipulated. We can apply different mathematical algorithms to help isolate the unknown signal.



### Resolution Bandwidth (RBW) Filter

Following the ADC is the resolution bandwidth (RBW) filter. The purpose of the RBW filter is to isolate the IF and reject any out-of-band signals. It can be implemented as the final stage of the IF filter, or further down the signal chain, depending on the design.

The RBW filter is a bandpass filter that allows frequencies within its envelope to pass through the filter but rejects frequencies outside of the envelope. The RBW filter commonly implements a Gaussian shape, as shown in **Figure 3-13**.

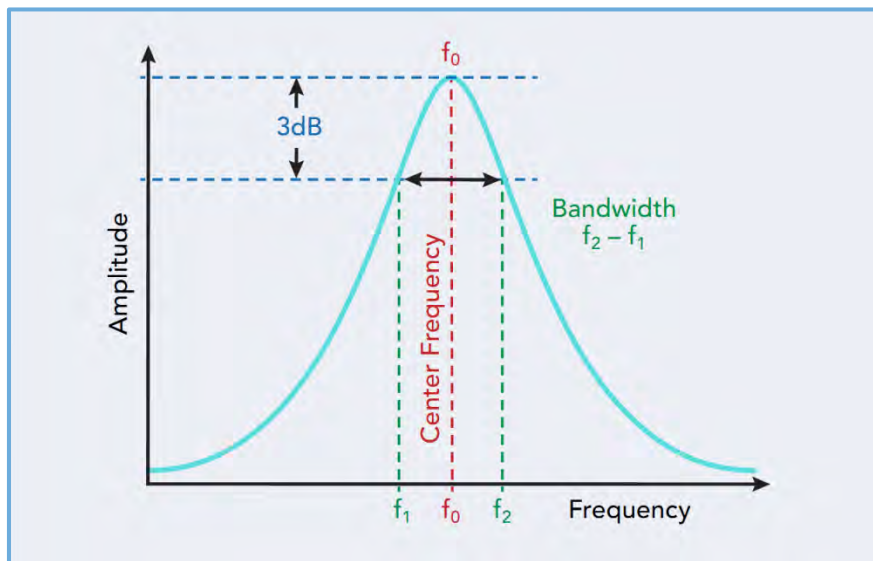

**Figure 3-13: Typical Gaussian RBW filter shape.**

A bandpass filter has a center frequency and a bandwidth. Typically, the bandwidth is given at the filter's 3dB point. The 3dB point is the amplitude at which the area of the curve is split in half. Fifty percent lies above the 3dB point, and 50 percent lies below the 3dB point.

The bandwidth is defined as the frequency difference ( $f_2 - f_1$ ) at the 3dB point.

The Gaussian filter shape is used because it offers the greatest degree of phase linearity balanced with good selectivity. Selectivity is a measure of how well a filter rejects signals that are near the operating frequency range of the filter. Other filter shapes (flat top, for example) have better selectivity, so they can reject out-of-band signals more precisely, but they do not have good phase linearity, which can cause undesirable effects like ringing that cannot be filtered out easily.

Although very popular, there are also other filter types that can be implemented using analog, digital, or a combination of both in a hybrid design.

Digital filters can be designed to have better selectivity than analog filters (**Figure 3-14**).

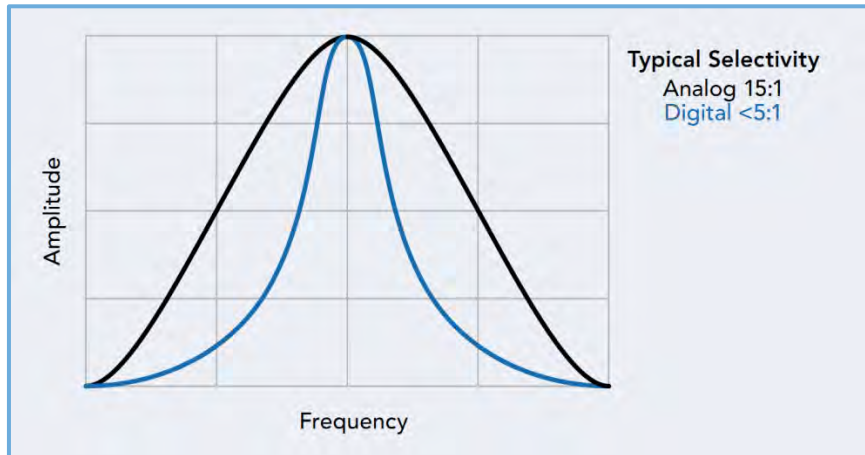

**Figure 3-14: Analog (black) vs. digital (blue) filter shapes. Note that digital filters can achieve higher directivity than analog filters.**

Digital filters also offer other advantages. For example, many electromagnetic compliance (EMC) tests typically use a 6dB Gaussian filter. This filter bandwidth is defined at the 6dB point, where approximately 75 percent of the area of the filter is higher than the 6dB point. This type of filter has a more desirable response to impulse and short duration burst RF signals, which can be a major contributor to electromagnetic interference (EMI).



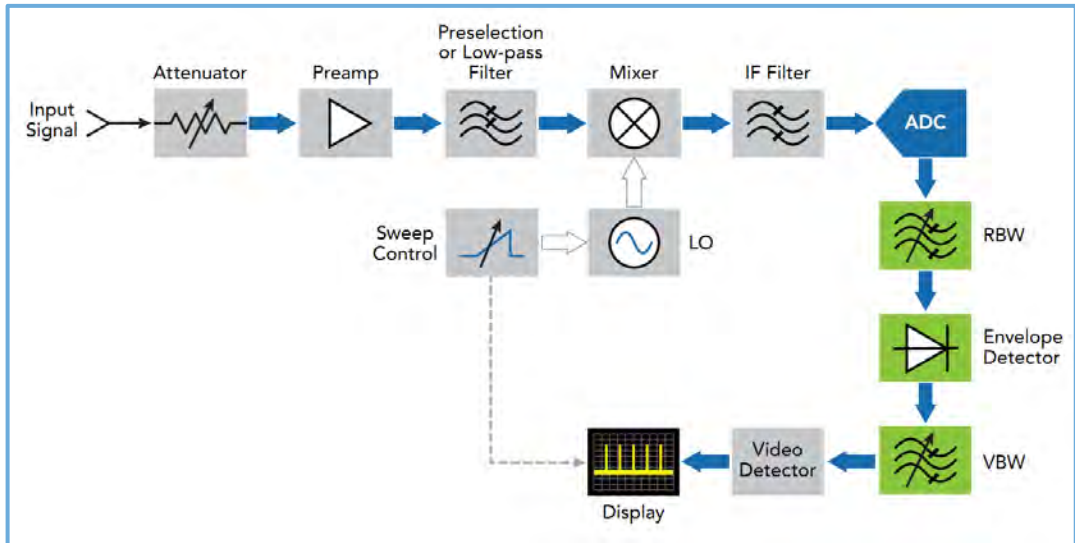

Figure 3-15: Block diagram of a swept superheterodyne design showing the location of the final stage of filtering and detector (RBW, Envelope, and VBW).

Figure 3-16 shows a screen shot from a swept spectrum analyzer. The input signals are 40MHz and 40.1MHz sine waves.

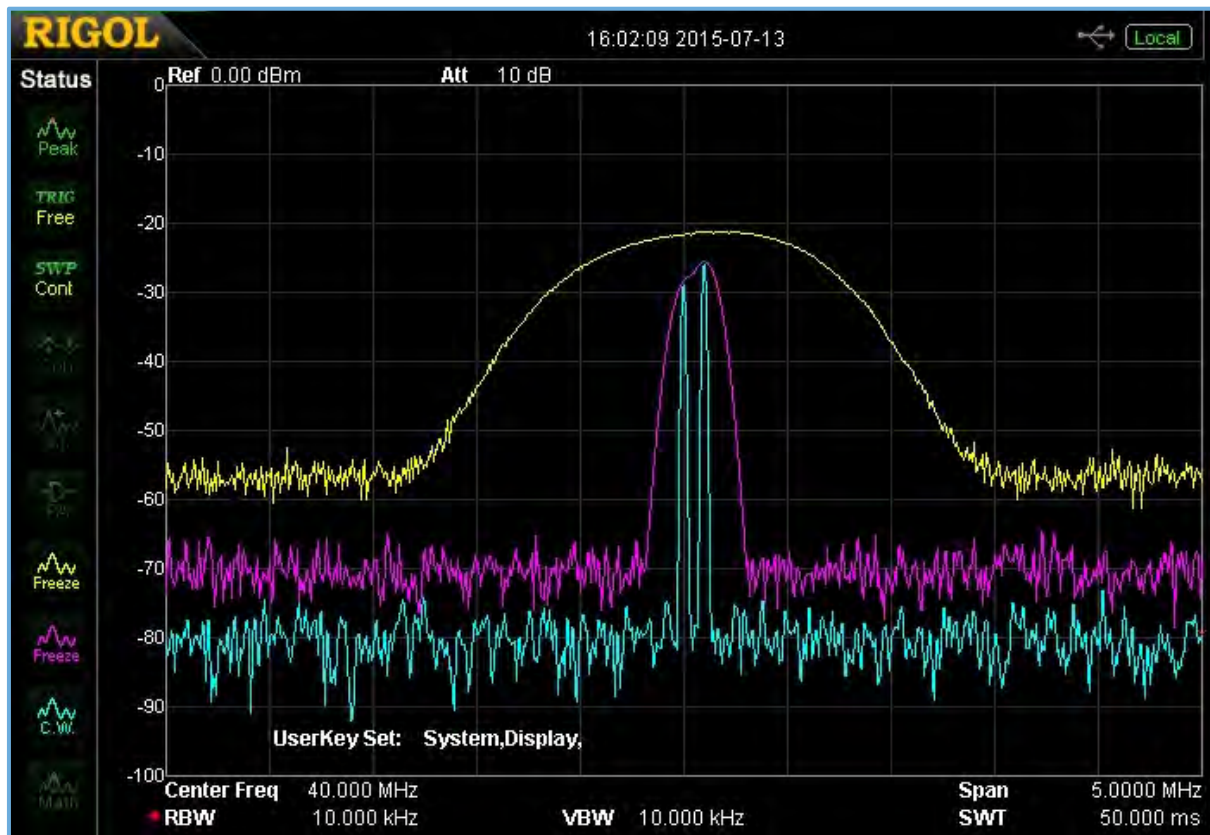

Figure 3-16: Two input signals scanned with RBWs of 1MHz (yellow), 100kHz (purple), and 10kHz (blue). The yellow trace was captured using an RBW of 1MHz. The purple trace was at an RBW of 100kHz, and the light blue trace was at 10kHz.

Because the signals are only separated by 100kHz, the RBW of 1MHz shows just a single bump because the RBW is greater than the input signal. This shape is characteristic of the swept IF frequency tracing out the envelope filter that follows the RBW filter.

As the RBW decreases, we get higher frequency resolution and lower noise floor, as you can see in the purple (RBW = 100kHz) and blue (RBW = 10kHz) traces.

## The Details of a Sweep

As mentioned earlier, we could implement a design that uses a filter for each frequency step of interest. This approach might be acceptable for analyzing a few hundred kilohertz of range, but it would be difficult and expensive if it had to work over a larger frequency range. For example, if we wanted to have the 100Hz of frequency resolution over 100MHz of operating range, that would require a million filters, which would not be very practical to implement in hardware.

As an alternative, the swept superheterodyne resolution bandwidth filter (RBW) has a fixed center frequency that does not change and also incorporates a user-defined range of bandwidths that provide resolution selectivity. This allows the designer to use a filter with better performance and a wider operating range to maximize the usefulness of the analyzer. Instead, the LO is swept across a frequency range in steps that are synchronized with the display steps. The actual sweep range frequencies for the 1st LO (swept LO stage) are typically not the same as the sweep range on the display. The LO sweep range is selected to be out of the measurement range of the instrument to help minimize noise and harmonics from the RF input.

Let's consider an example where an analyzer is configured to sweep from a start frequency of 1GHz to 1.5GHz. The RBW is fixed at 500MHz, and the LO sweeps from 500MHz to 1GHz as shown in **Figure 3-17**.

At the first step in the sweep, the  $RF_{IN}$  is 1GHz, LO is 500MHz, and the resultant IF is 500MHz.

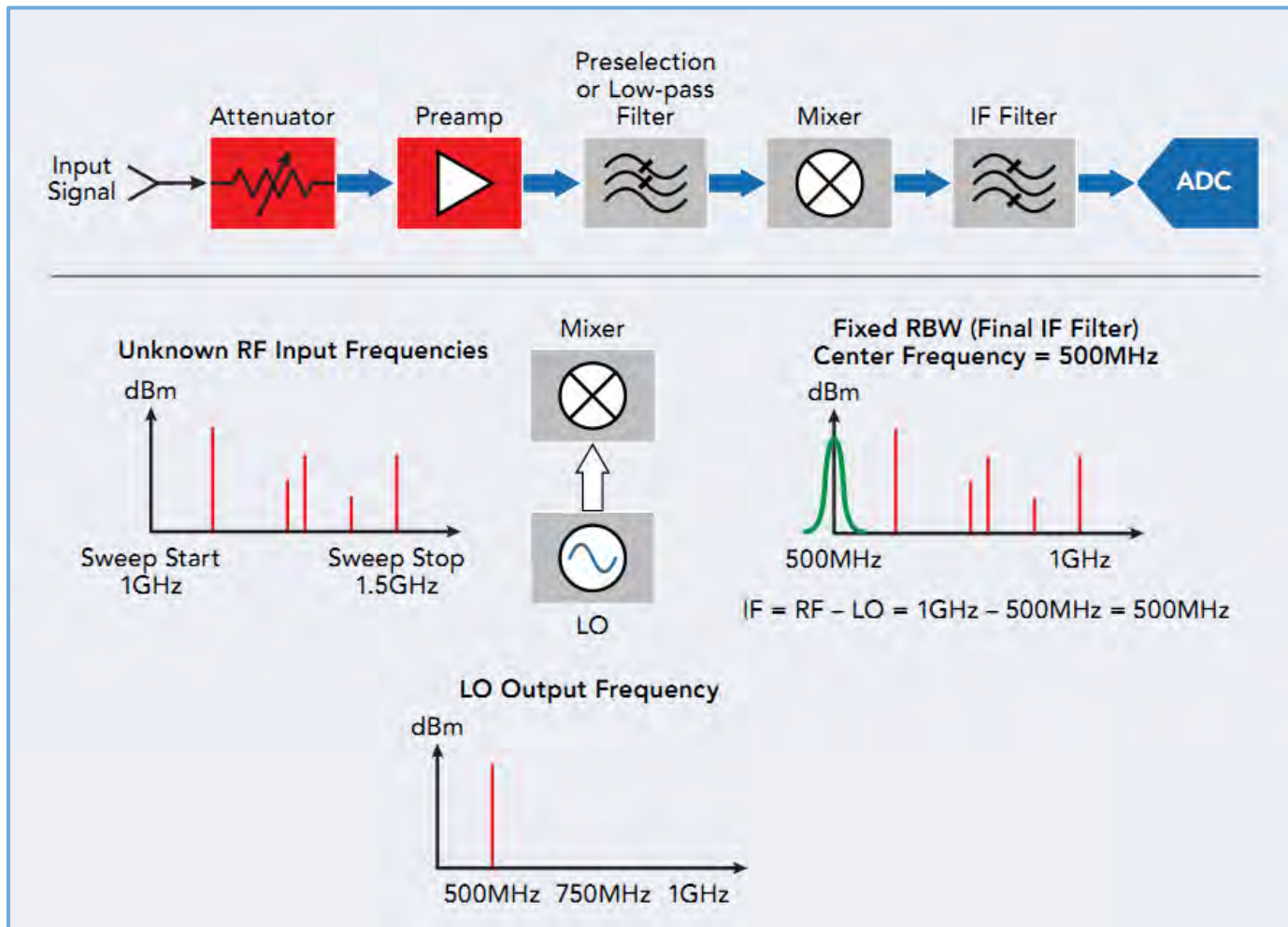

Figure 3-17: Block diagram showing the unknown inputs, LO, and the IF output. Note the RBW filter at a fixed frequency (green). Note: The LO sweep spans the same frequency range as the display range on the analyzer.

The LO continues to sweep with the display. When the LO is at 750MHz, the IF has signals present near the RBW/IF filter center wavelength, as shown in **Figure 3-18**.

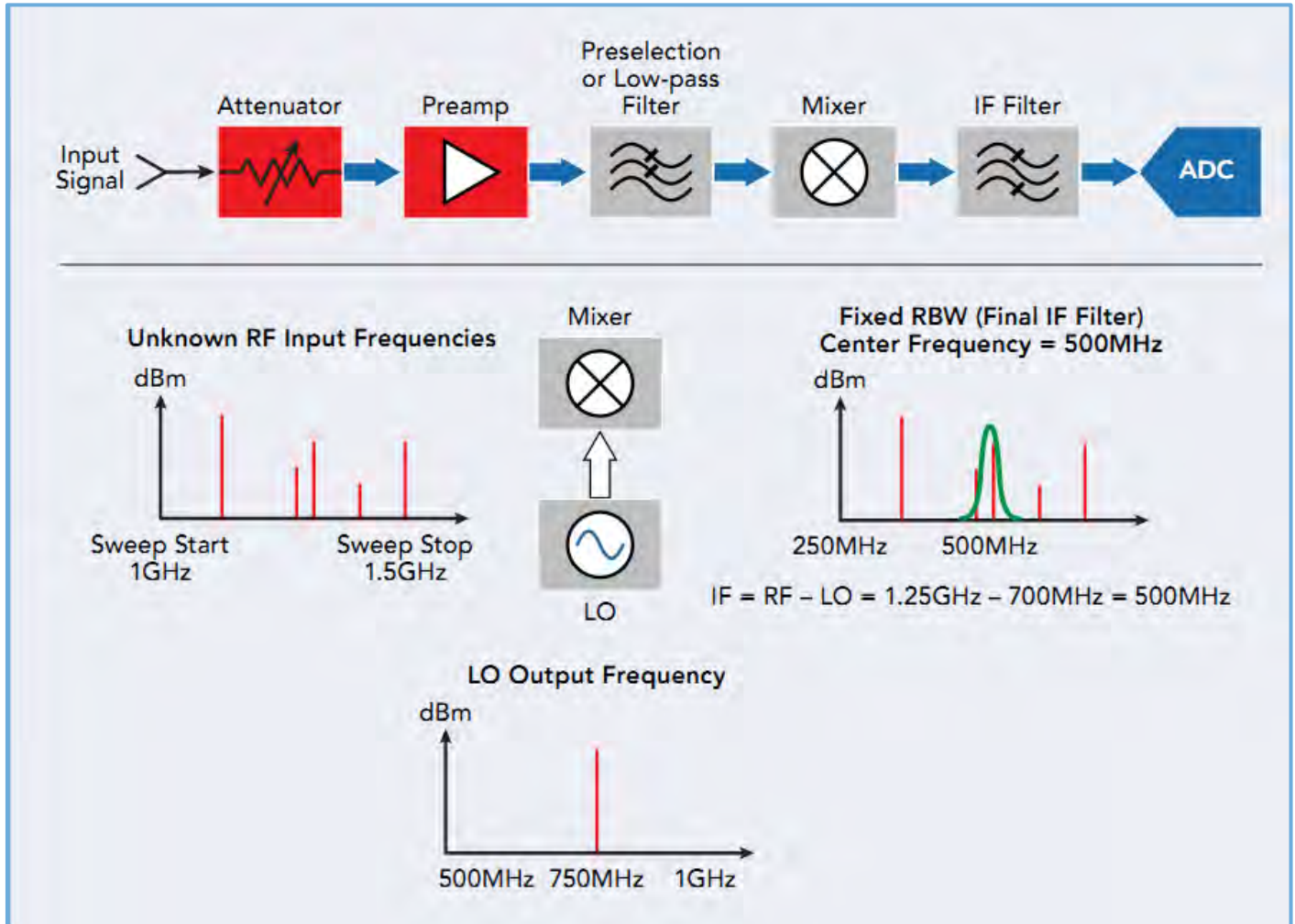

Figure 3-18: The unknown RF input signals are mixed with the LO to create the IF. The IF is then compared with the RBW filter.

This process continues through the entire scan range.



Figures 3-19 and 3-20 show the same steps, as well as the actual displayed spectrum on the analyzer.

**Note:** In frequency bins where there are no RF<sub>IN</sub> signals, the display shows the noise floor of the analyzer.

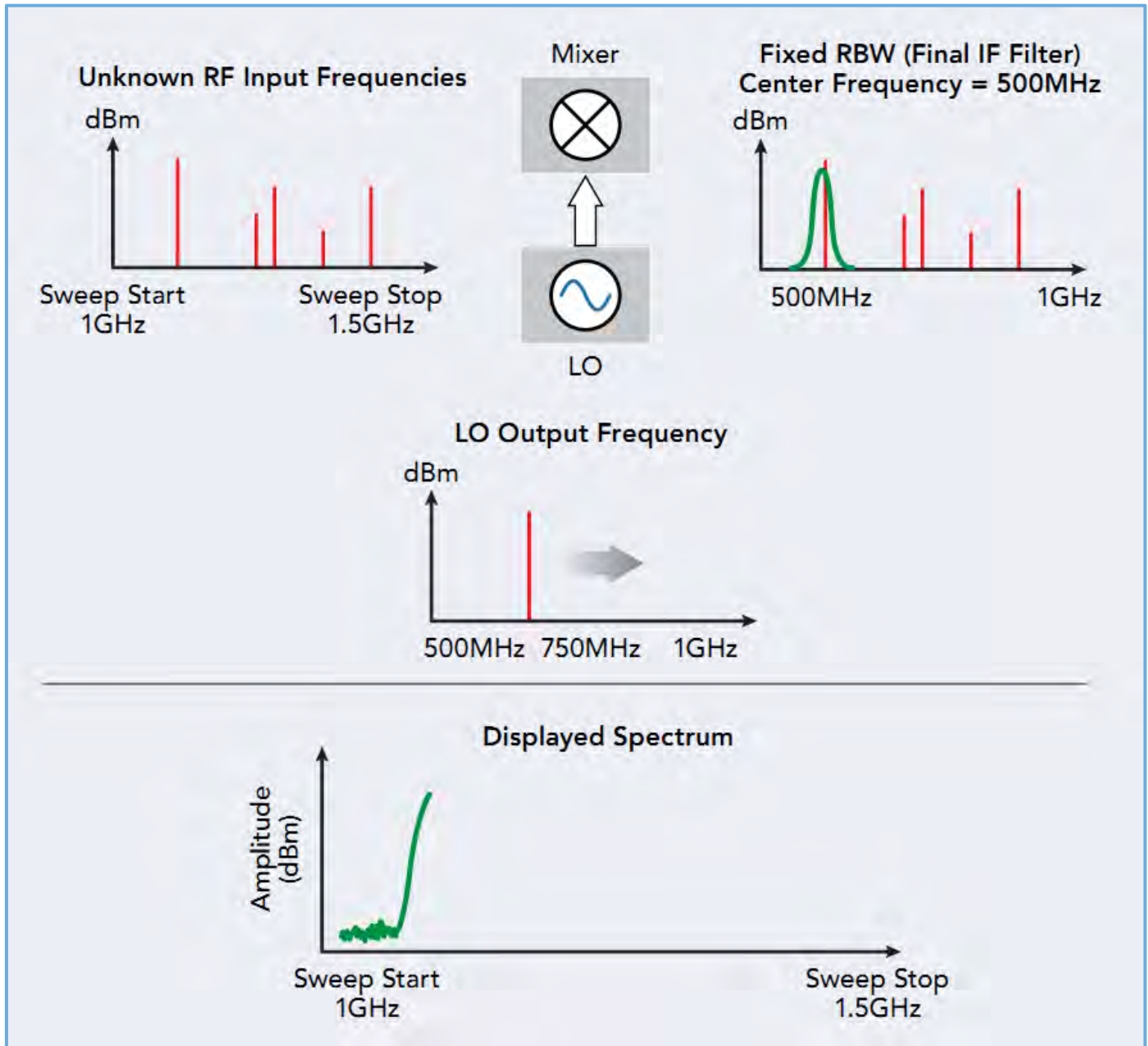

Figure 3-19: The displayed spectrum as the analyzer scans across the operating frequency range.

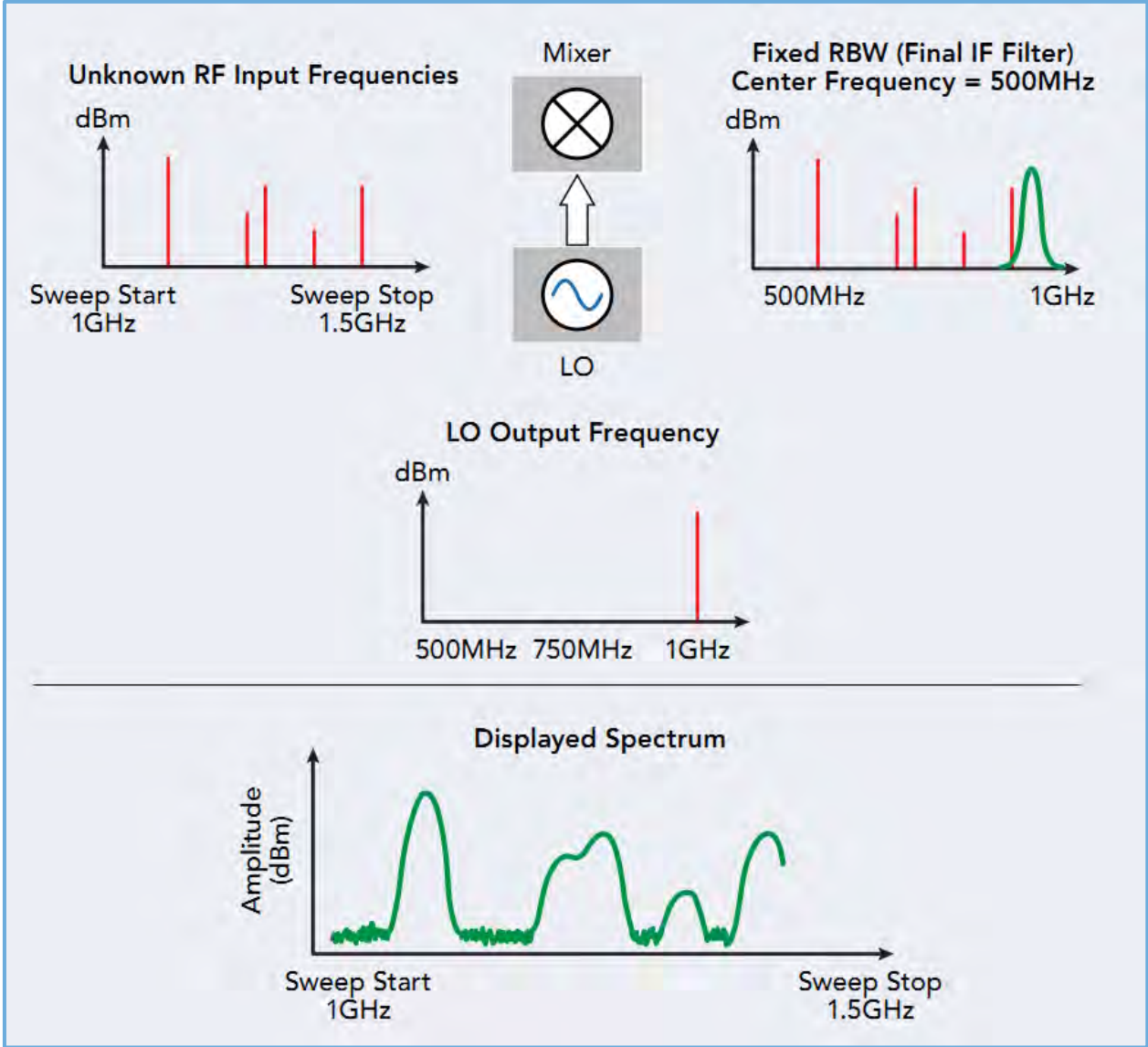

Figure 3-20: A completed sweep showing the RBW filter's effect on the displayed data (green).

Narrower RBW bandwidths provide higher frequency resolution and a lower noise floor, but they increase the sweep time for a given span because they increase the number of steps required to cover that span.

### The Envelope Detector

Immediately following the Resolution Bandwidth filter (RBW) is an envelope detector, which measures the voltage envelope of the time-based input IF.

If the IF is a single frequency sine wave, the output will be a single DC voltage. This is the situation when the IF is simply the LO, with no mixed frequencies present.

If the IF is comprised of multiple frequencies, which is the case if there are mixing products in the IF ( $f_{LO} - f_{sig}$  or  $f_{LO} + f_{sig}$ ), then the output voltage will match the envelope of the IF in time, as shown in **Figure 3-21**.

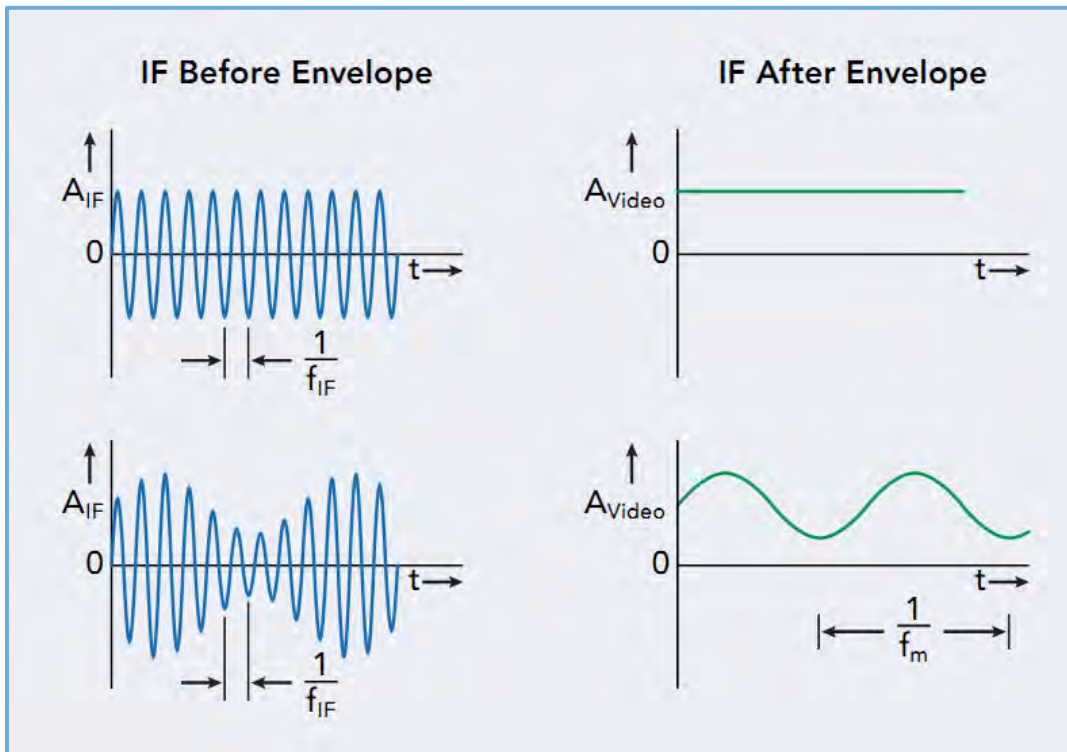
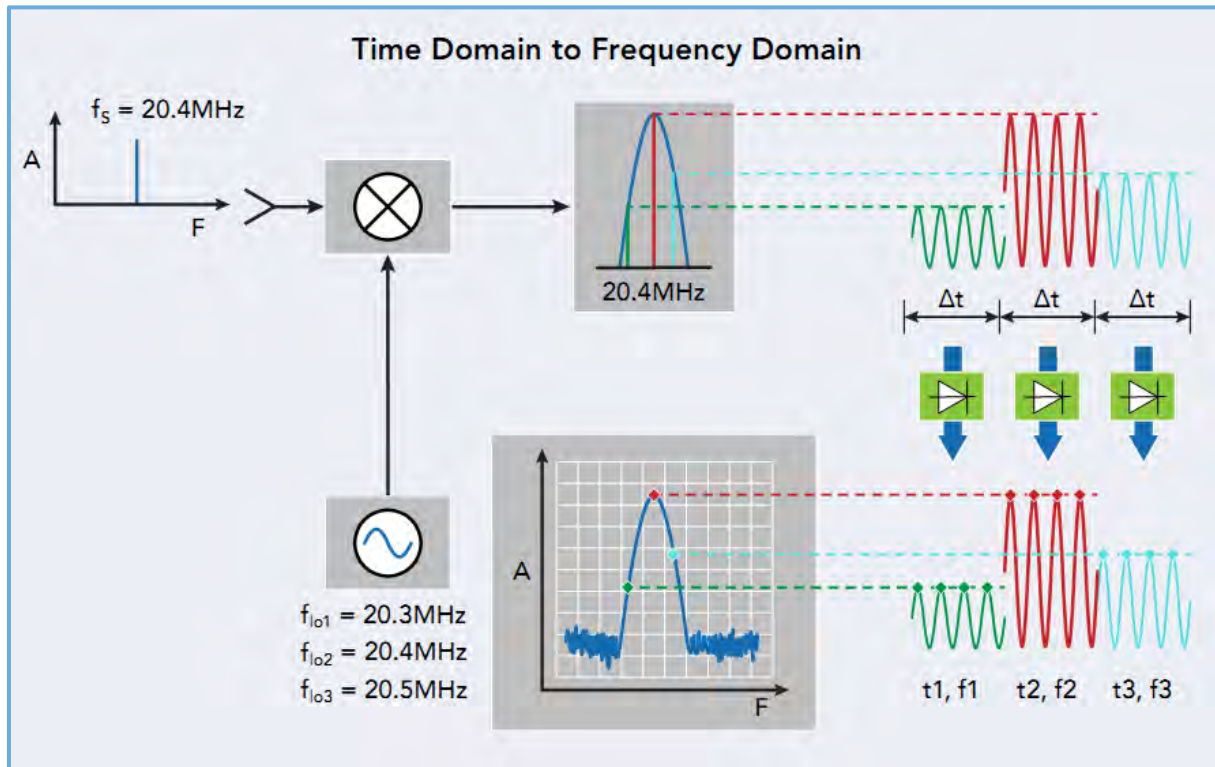

Figure 3-21: The intermediate frequency after the envelope detector.

Now, let's look at how the sweeping LO, RBW filter, and envelope work together to convert the signal from the time domain to the frequency domain.



**Figure 3-22** shows an example of an unknown signal ( $f_s$ ) as it is mixed with three steps ( $f_{lo1}$ ,  $f_{lo2}$ , and  $f_{lo3}$ ) of a sweeping LO.



**Figure 3-22:** An unknown signal is mixed with three LO steps showing how the data from the envelope detector data is selected for display.

The envelope detector returns the voltage value of each of steps ( $f_{lo1}$ ,  $f_{lo2}$ , and  $f_{lo3}$ ) in this sweep. At each step in the LO, the amplitude (voltage) is plotted vs. the step frequency.

Many analyzers have a number of detectors available that allow selecting the voltage values that are displayed from each frequency bin that has been collected.

**Figure 3-23** shows the video voltage of a signal for two frequency bins,  $f_0$  and  $f_1$ . The top plot shows the video voltage (green trace) of this incoming signal with respect to time. The bottom plot shows the value that each detector selection would report to the display.

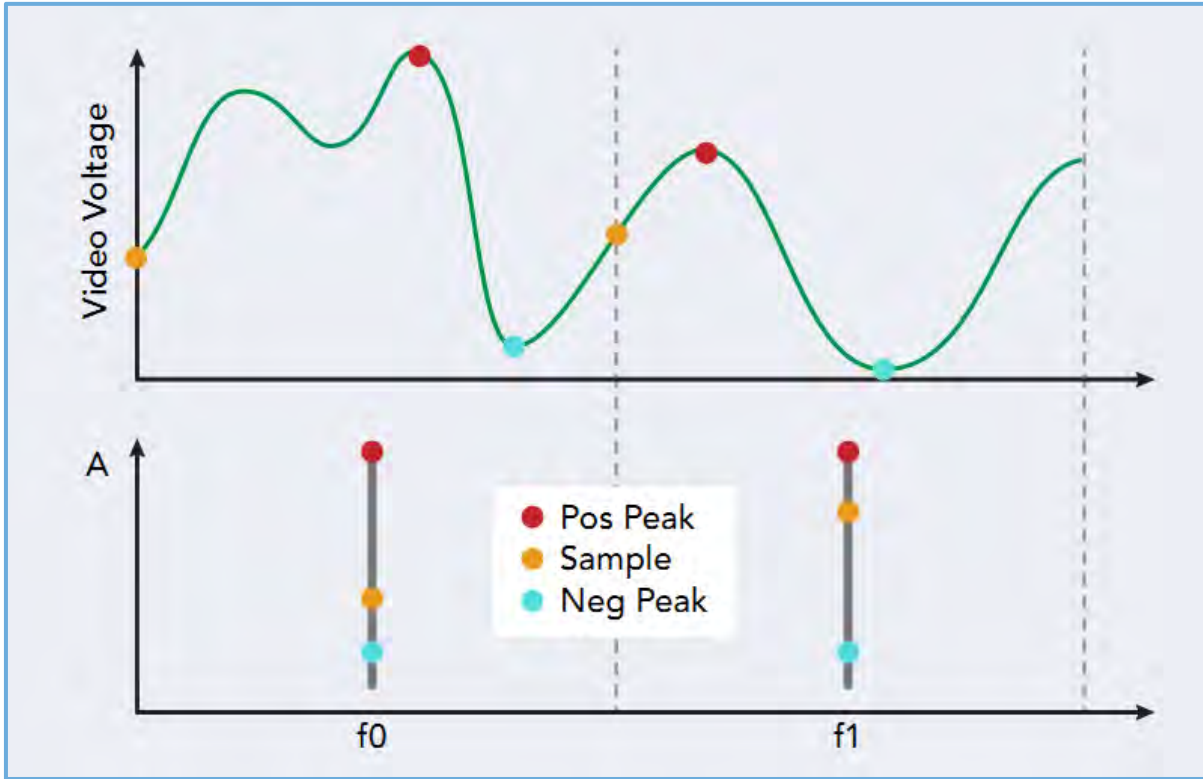

Figure 3-23: The video voltage is selected based on the detector type. This diagram shows the data displayed based on a Positive Peak, Sample, and Negative Peak detector selection for a given input signal.

The positive peak detector displays the maximum amplitude value in each bin. It is useful for sinusoidal inputs, but it is not recommended for noise because it will not show the true random nature of a noise source.

The negative peak detector displays the minimum amplitude value in each bin.

The sample detector will select a random value from the video voltage. It is most useful for observing noise.

The normal or “rose-and-fell” detector will select either the positive or negative peak values, depending on the trend within that bin. If the signal both rose and fell within that bin, it will assume that the input is noise and will alternate between positive and negative peaks to provide a more appropriate response to the input. If it rose within the bin, it will select positive; if it fell, negative. It is most useful for noise and sinusoidal signals.

There can also be averaging detectors, such as RMS average, voltage average, and Quasi-Peak average detectors.

The RMS detector reports the root-mean-square (RMS) value of the incoming signals. It is useful when measuring the power of communication and other complex signals.

The voltage average reports the average, or mean, voltage of the bin. It can be helpful for electromagnetic interference (EMI) measurements.

Some specialized analyzers also come with a Quasi-Peak (QP) detector, which provides a special weighted average of the data in each bin and is specifically used for electromagnetic compliance (EMC) testing. It should be noted that the QP detector has a fixed integration time that is significantly longer than the standard detector types. It will increase sweep time considerably.

Detector Selection	
Sample	Noise
Peak	Sinusoidal Signals
Negative Peak	CW from an impulse
Normal	Noise and Sinusoidal Signals
Voltage Average	EMI/Pulsed signals
RMS Average	Power measurements for complex signals
Quasi-Peak	EMI and Compliance Signals

Figure 3-24: Suggested detectors for specific applications.

## Video Bandwidth (VBW)

The Video Bandwidth (VBW) filter is a low pass filter that is applied to each frequency bin before sending the appropriate amplitude value to the display. It effectively averages (smoothes) the signal and can be used to minimize the effects of noise on the displayed trace. It is especially useful when dealing with low power signals that are close to the noise floor of the instrument.

Figures 3-25 and 3-26 compare a 20MHz sine wave input captured at a VBW of 100kHz and 1kHz respectively. Note how the VBW smooths the trace and makes it easier to see the true signal.

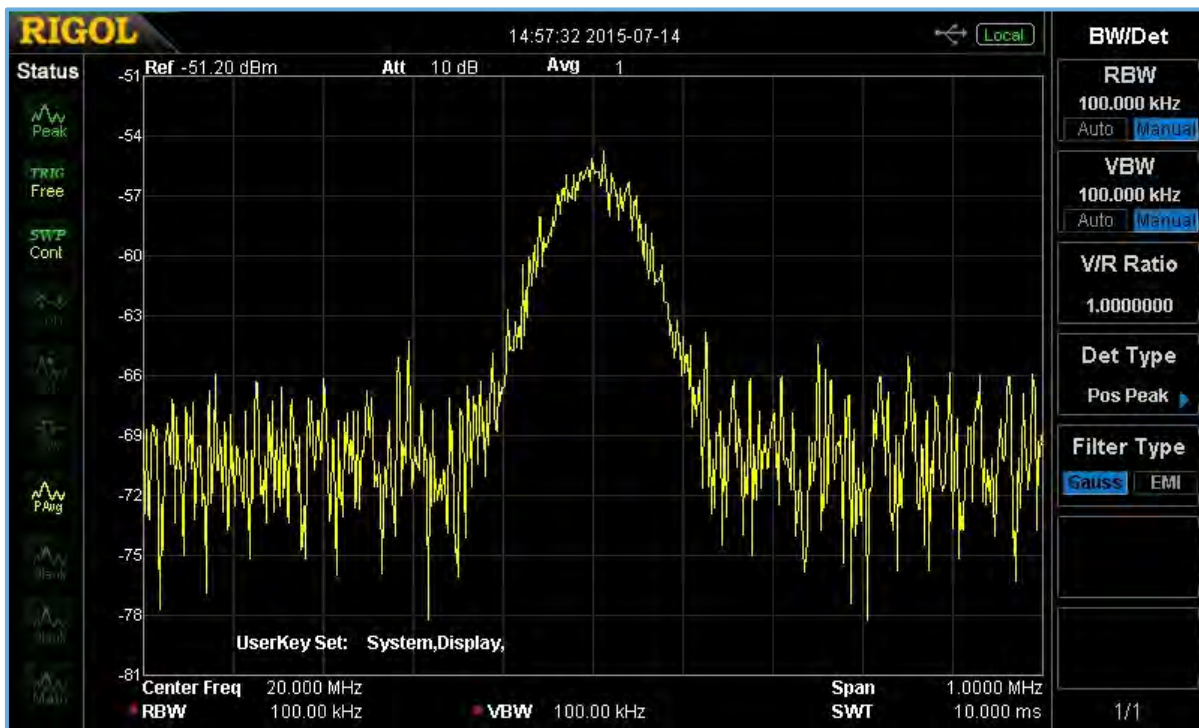

Figure 3-25: 20MHz input on a spectrum analyzer with VBW set to 100kHz.

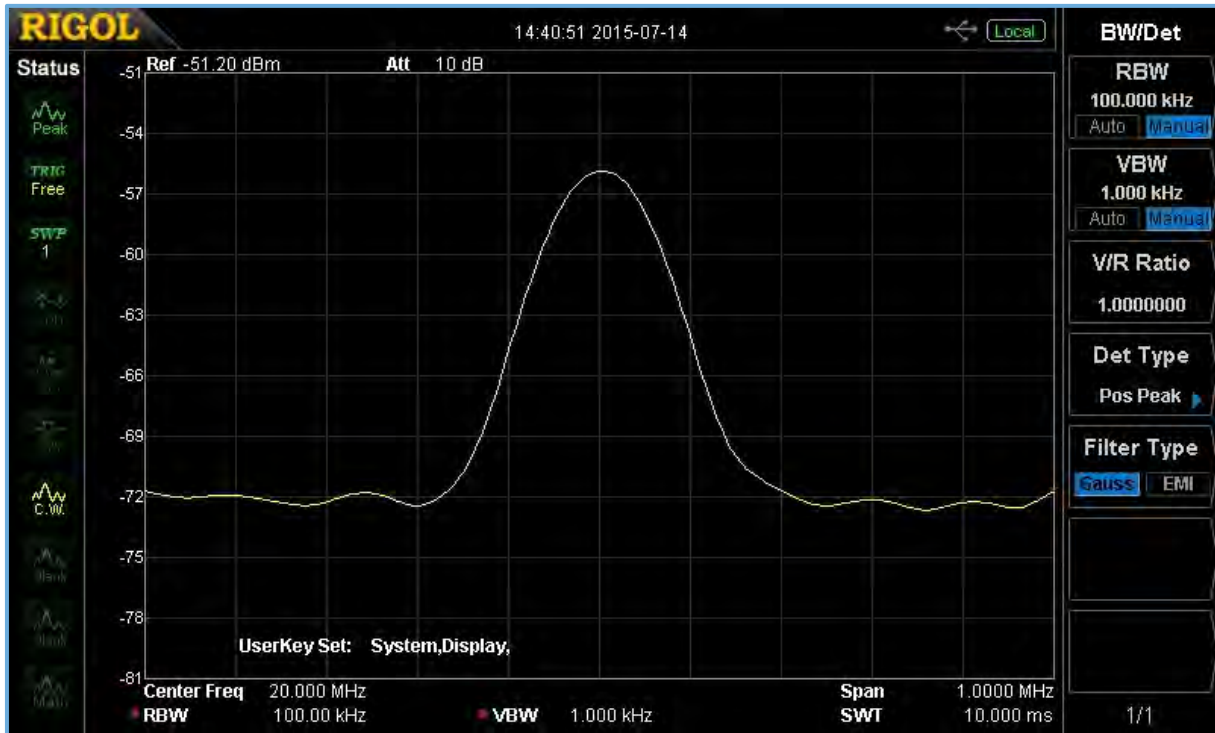

Figure 3-26: Identical 20MHz signal with the VBW decreased to 1kHz. Note smoothing of the trace.

Note that decreasing the VBW setting can increase the sweep time.

Many analyzers also provide the ability to average a number of traces when using an Averaging Detector like RMS or Voltage.

Averaging traces has a similar effect to lowering the VBW setting, as shown in **Figures 3-27** and **3-28**, but this technique can require successive scans, which can lead to a longer total test time.



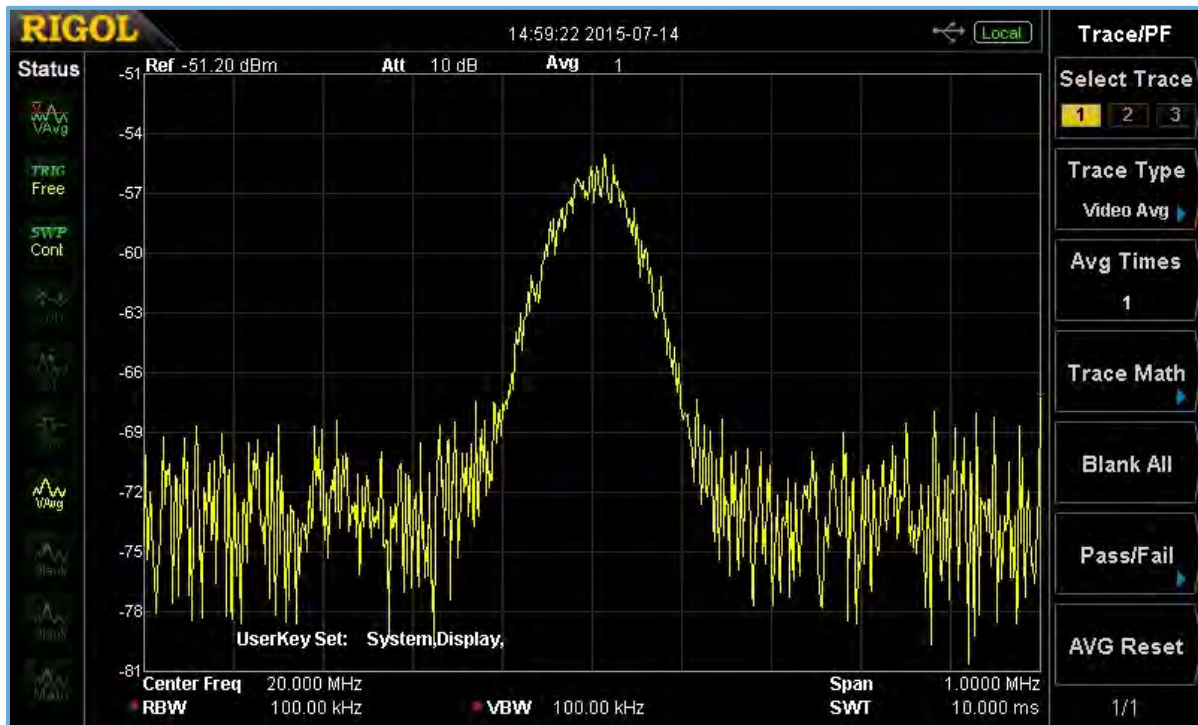

Figure 3-27: A 20MHz input signal with no averaging applied.

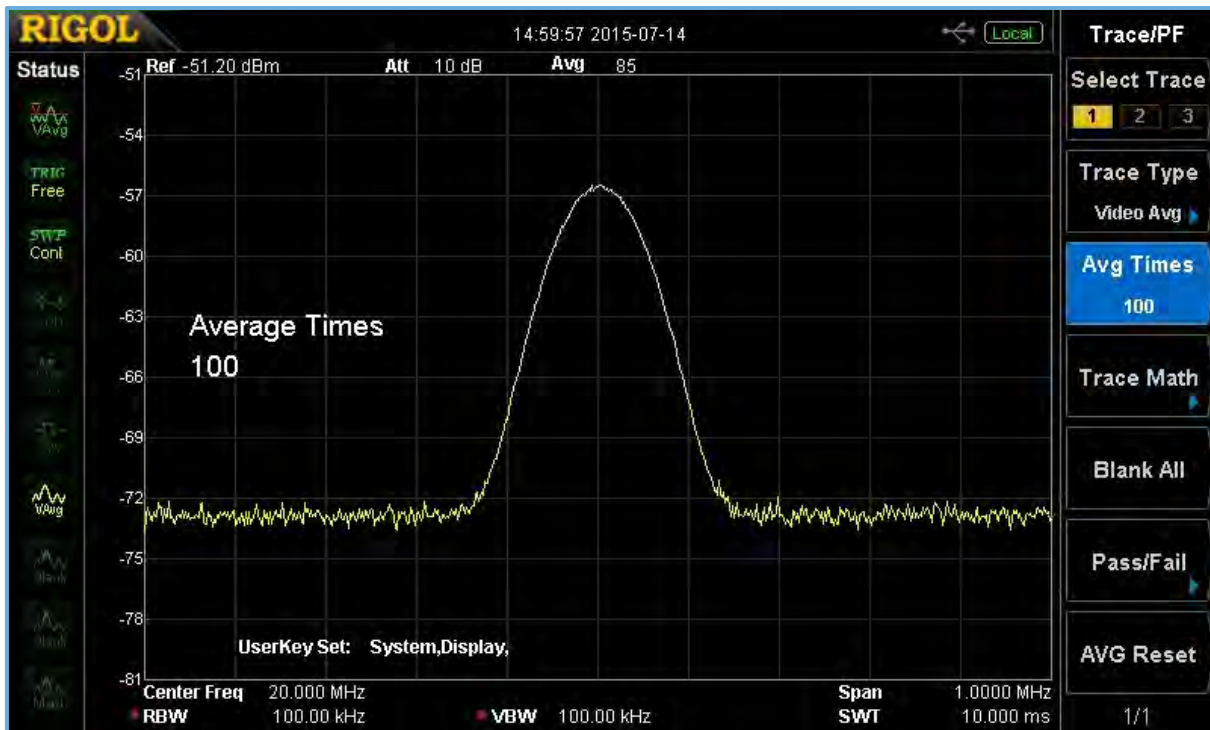

Figure 3-28: A 20MHz input signal with 100 averages applied. Note that the noise on the trace has decreased significantly.

## Noise

When making measurements, it's important to limit the error and decrease the effects of unwanted signals in order to get the most accurate representation possible. Some sources of noise are part of the instrument itself (internal); others are external. This discussion will address only internal noise sources.

One of the main sources of noise is thermal effects in the circuit elements within the instrument. Essentially, temperature is a measure of the average kinetic energy of a system. On a molecular level, higher temperatures lead to higher average kinetic energy due to an increase in molecular vibrations. These vibrations create electrical potentials (voltage) that can effect measurements.

Thermal (also known as Johnson) noise is defined by this equation:

$$P_n = kTB$$

Where  $P_n$  = Noise power in watts

$k$  = Boltzmann's Constant ( $1.38 \times 10^{-23}$  joule/°K)

$T$  = Absolute temperature, °K

$B$  = Bandwidth in Hz

Let's look at two examples.

What is the noise power of a system with  $T = 293^\circ\text{K}$  (equivalent to room temperature of  $20^\circ\text{C}$  or  $68^\circ\text{F}$ ) and a measurement bandwidth of 1MHz ( $1 \times 10^6$  Hz)?

$$P_{n1} = 1.38 \times 10^{-23} \text{ joule/}^\circ\text{K} * 293^\circ\text{K} * 1 \times 10^6 \text{ Hz} = 4 \times 10^{-15} \text{ watts}$$

Let's say we cut the bandwidth by 10:  $B = 100\text{kHz}$  ( $1 \times 10^5$ )

$$P_{n2} = 1.38 \times 10^{-23} \text{ joule/}^\circ\text{K} * 293^\circ\text{K} * 1 \times 10^5 \text{ Hz} = 4 \times 10^{-16} \text{ watts}$$

Now, what if we compared these two powers in dB?

The equation for power in dB is  $L_p = 10 \log_{10} (P/P_o)$ dB.

Using the results from our experiment, the result is:

$$L_p = 10 \log_{10} (P_{n1}/P_{n2})\text{dB} = 10 \log_{10} (4 \times 10^{-15} \text{ watts}/4 \times 10^{-16} \text{ watts}) = 10\text{dB}$$

As you can see, the bandwidth of the measurement directly affects the thermal noise that can influence the measurement. In order to increase sensitivity (synonymous with decreasing noise), we can l



The Displayed Average Noise Level (DANL) of a spectrum analyzer is a term that describes the expected noise level of the analyzer and it determines the lowest signal level that can be measured by the instrument.

The DANL represents the noise floor of the instrument. The DANL value is heavily influenced by the frequency span of the measurement, RBW, VBW, preamplifiers, and detector settings but can also be affected by factors such as the number of trace averages being used.

It's possible to lower the DANL quickly by decreasing the RBW setting. Decreasing the RBW by 10 times will decrease the DANL by 10dB as shown in **Figure 3-29**.

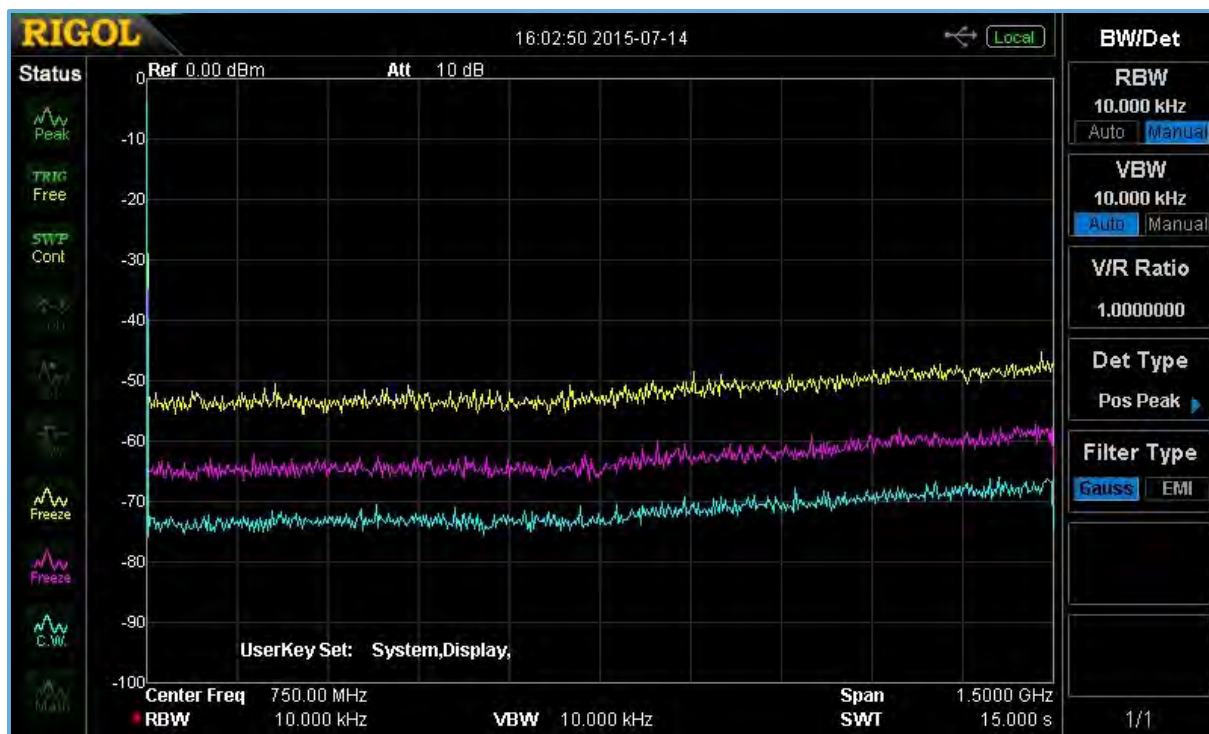

**Figure 3-29:** Noise floor differences on an analyzer with three RBW settings. RBW= 1MHz (yellow), 100kHz (purple) and 10kHz (blue).

In this experiment, there was no input signal to the analyzer, just the noise floor of the instrument. The yellow trace represents a scan from 9kHz to 1.5GHz with an RBW of 1MHz. The purple trace was acquired using an RBW of 100kHz and the light blue trace used an RBW of 10kHz. Note that each decade (10) decrease in RBW resulted in a 10dB drop in the DANL.

## Sweep Speed

Decreasing the RBW has a dramatic effect on the noise floor, but it also increases the time that it takes for the instrument to scan over a specific frequency span. That’s because by decreasing the bandwidth of each step, we increase the number of steps we must perform to cover that span.

The sweep speed is determined by the span, RBW, and detector settings. Many analyzers will have default settings that will automatically set the sweep time to provide the best balance between sweep speed and amplitude accuracy. Short sweep times could be too fast for the IF stage to respond to the input and result in additional measurement error.

The first sweep (**Figure 3-30**) is a scan of a 20MHz sine wave with an amplitude of -10dBm. The automatic settings were used on the instrument and the resultant sweep time was 101.10ms.

The second sweep (**Figure 3-31**) is a scan of exactly the same input signal but with a different sweep time. It was forced to 10ms. Note that the amplitude error increased significantly and the spectral profile is quite different. The analyzer actually indicates that the sweep time is too fast for the settings with an UNCAL label in the top portion of the display.

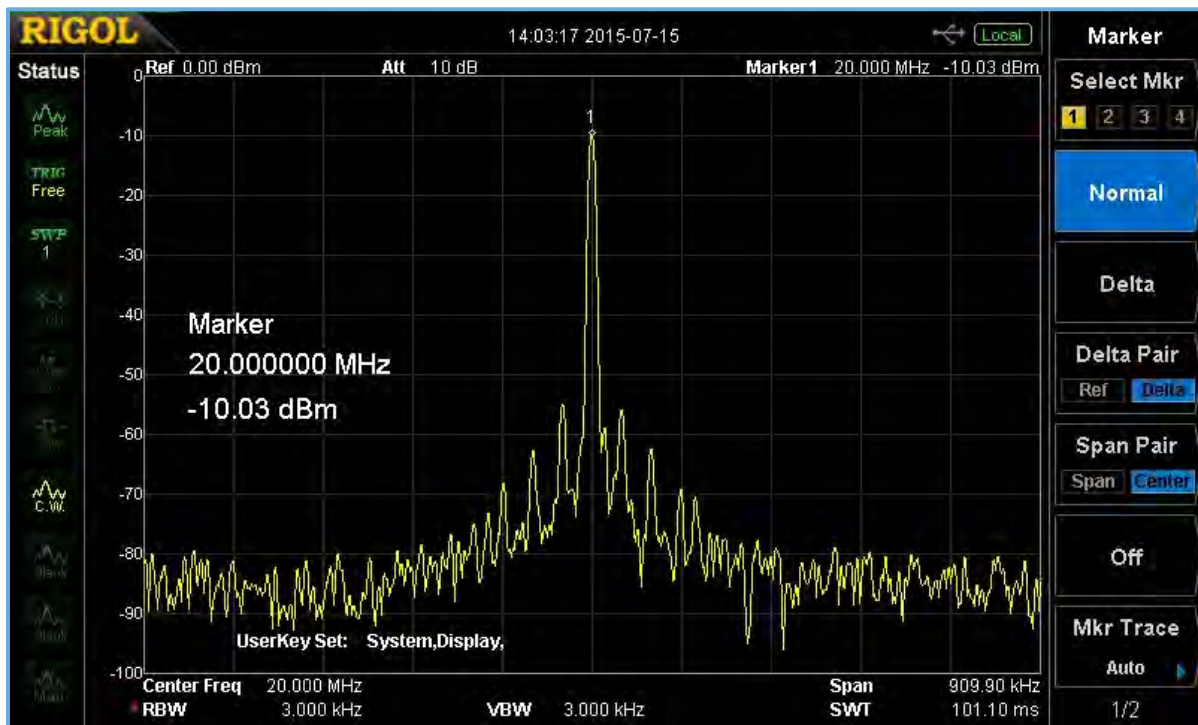

Figure 3-30: 20MHz sine input collected using the automatic settings on the analyzer.

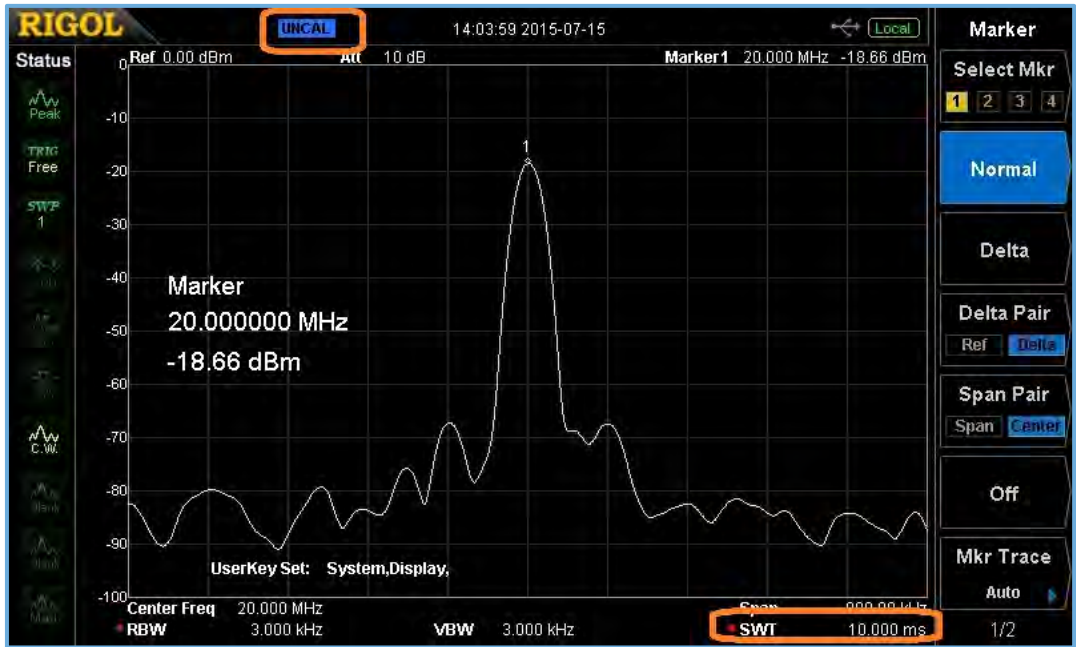

Figure 3-31: The same 20MHz sine input, but this time, the sweep speed was increased manually. Note that the instrument is notifying the user of UNCAL and there are amplitude and frequency errors due to the increased sweep speed.

To ensure the greatest accuracy, use the instrument’s recommended automatic settings.

## The Vector Network Analyzer

The swept superheterodyne design described previously captures amplitude and frequency information. These measurements are also known as scalar measurements because they do not capture phase information for the incoming signal. Instruments that capture amplitude vs. frequency are therefore known as Scalar Network Analyzers.

A host of applications require capturing the incoming signal phase information in addition to the amplitude and frequency. This is especially important for proper demodulation of digital communications and for characterizing components used in digital systems. The Vector Network Analyzer (VNA) is widely used for these applications.

The VNA is based on a swept superheterodyne design. The main difference is that the VNA uses an extra stage in the signal path that collects and stores phase information for the incoming signal.

VNAs are useful for measuring the performance of RF components, commonly called the scattering or S-parameters, as well as measuring the performance of digital communications signals.

## Chapter 4: Spectrum Monitoring with Real-Time Analysis

Today's RF engineer is confronted with the challenge of how to transport ever increasing amounts of data across local and wide area networks. For IoT applications the most common way is to use wireless transmission of data via common standards like Bluetooth, Wi-Fi or Zigbee. Wireless transmission works with digitized data which is then modulated to an RF carrier via complex modulation schemes. These signals then vary rapidly in frequency to deal with the congestion of the unlicensed ISM Band spectrum. These factors combine to generate very fast and dynamic signal change over time and frequency band. Since a traditional swept spectrum analyzer measures power at just one frequency at a time even the fastest sweeping analyzer leaves blind time where transient and hopping signals can be missed.



**Lost information at same time**

**Sweep point after 600  $\mu$ sec.**

Figure 1: Sweep result of spectrum analyzer with blind time

For example while a fast changing frequency hopping signal like Bluetooth can be measured with SA it is severely limited. One trace can be set to maximum hold. A second trace can be set to clear write. With one sweep it is not possible to capture all signal components. Multiple sweeps are necessary to build up an image of the spectrum (see figure 2). So while you have built up a view of the spectrum over time not all frequency components are visible, there is no time information available and it is not possible to detect that this signal is a frequency hopping spread spectrum signal.





Figure 2: Bluetooth signals are only visible via max hold function with SA

Certain signals which are only randomly available and very fast may never be detected. Additionally, Frequency, Span and RBW have a direct influence to sweep time on a swept spectrum analyzer. So if a finer frequency resolution is required, then RBW needs to be decreased. This results in a lower sweep time making the capture of those fast changing signals even less likely.

### Real- Time Capture and Analysis

Real Time spectrum analyzers capture data across the entire real-time span then uses an FFT (Fast Fourier Transform) to display power over the entire span. Since all frequency components are calculated from the same data capture it is simple to see the transient signals that are occurring and since it is captured in time it possible to quickly visualize signal behavior over time. But the calculation is accomplished differently different than a scope based FFT. In a scope based FFT calculation time is required between FFT acquisitions to create

and Display the FFT. This creates an acquisition GAP and some parts of the signal will be lost (*see figure 3, below*). This means a standard scope based FFT also can't be used for measurement of pulsed signals because, as with swept analyzers signals can be missed in the gaps between FFT acquisition.

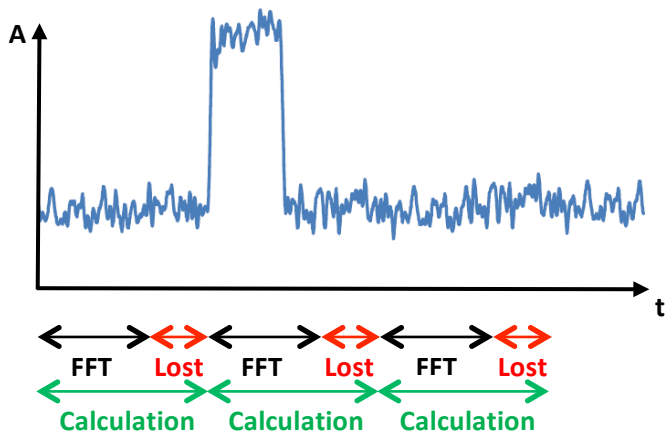

Figure 3: FFT with gaps in between based on slow calculation process

In real time analysis multiple FFT acquisitions and calculations are performed in parallel and overlapping. The Real-time analyzer contains additional processing capability to handle this additional workload to capture, calculate and display the results results in real-time. The result is that time acquisition of different FFT blocks is **Gap Free** (*see figure 4 below*) and performance will not be affected by choosing using different RBW settings.

Gap free FFT example in real time operation:

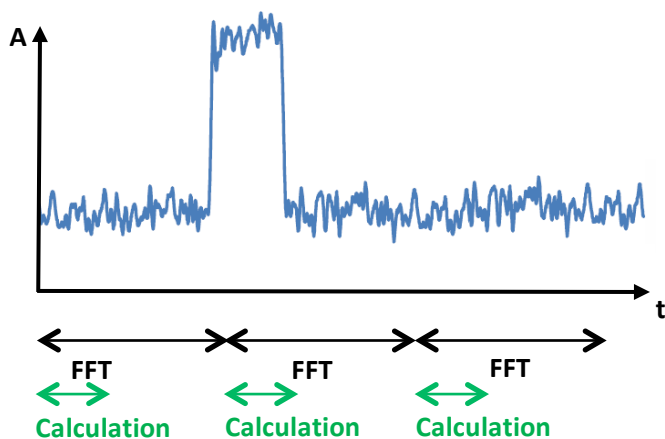

Figure 4: FFT in Real time spectrum analyzer without gaps



A fixed number of 1024 samples are used for one FFT time acquisition. Each FFT calculation is using a window function. Windowing is important to define a discrete number of time points for calculation. Size of window can be varied and is not fixed in time domain. A variation of window size will have a direct influence of real time resolution bandwidth [RBW] or the other way around: with changing the RBW, size of window will be changed.

The position of a time signal like a pulse needs to be in the center of FFT window to transform it correctly into frequency range. In case that a pulse is in between two FFT events, then amplitude is suppressed by filter side loops and is no longer correct (*see figure 6*).

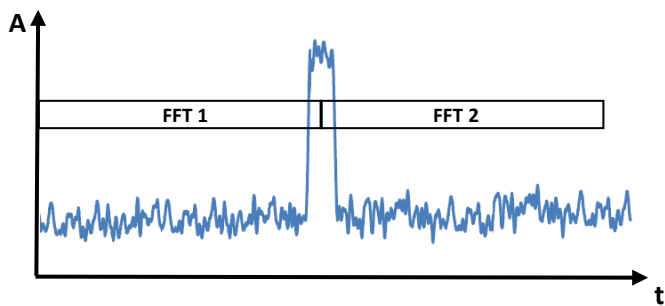

Figure 5: Amplitude is wrong if signal is located in between of two FFT blocks

An overlapping process of FFT events will be used in Real-time analyzers to avoid losing signal information. Overlapping has the effect that more spectrums are available over a time period and time resolution is higher. Smaller events can be measured (*see figure 7*) and signal suppression of single FFT acquisition occurred due windowing is eliminated with overlapping.

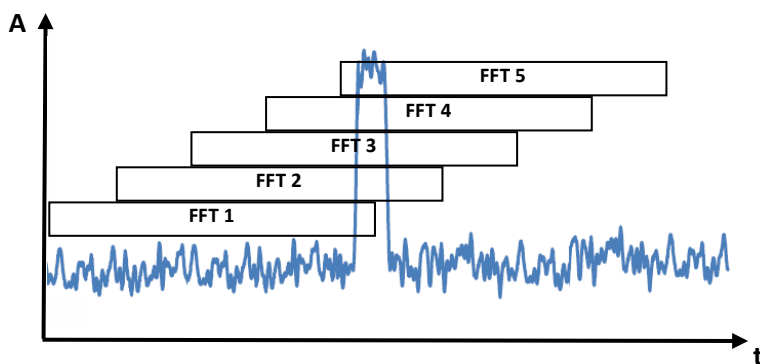

Figure 6: Overlapping process in real time spectrum analyzer

In other words, overlapping process of FFT events has a direct influence of smallest pulse width which can be measured with a real time spectrum analyzer. The RT-SA RSA5000 is working with a FFT rate of 146.484 FFT/sec. which results into a calculation speed ( $T_{calc}$ ) of 6,82  $\mu$ sec.:

$$T_{calc} = \frac{1}{FFT\ Rate} = \frac{1}{146.484 \frac{FFT}{sec.}} = 6,82 \mu sec.$$

Depending on real time span there are 4 different sample rates available. The maximum sample rate is 51,2 MSa/sec. With that sample rate and the fixed number of samples ( $N_{Fix} = 1024$ ), used for one FFT acquisition, the duration can be calculated as follow:

$$T_{acq} = \frac{N_{Fix}}{Sample\ Rate} = 1024\ Sa.* \frac{1}{51,2 \frac{MSa.}{sec.}} = 20 \mu sec.$$

An overlap of FFT frames is not possible during calculation progress. Therefore the overlapping time of FFT frames can be calculated with that formula:

$$T_{overlap} = T_{acq} - T_{calc}$$

For example with sample rate of 51,2 MSa./sec. the overlap time is 13,18  $\mu$ sec or 65,86% which results into  $N_{Overlap} = 674$  sample points.

### Probability of Intercept [POI]

POI specify the smallest pulse duration which can be measured with 100 % amplitude accuracy. Furthermore POI defines the minimum pulse width where each pulse will be captured (*see figure 8*). The smallest 100% POI of the RIGOL RSA5000 is 7.45  $\mu$ sec.

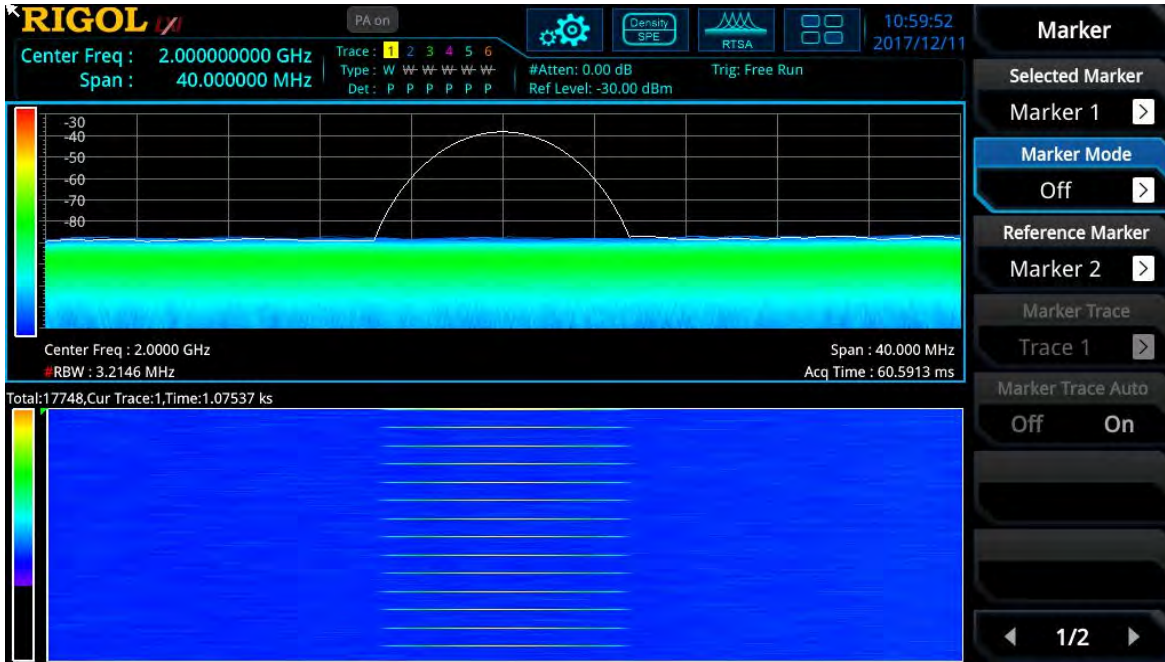

Figure 7: Measurement of a pulse of 7.45  $\mu$ sec. (period: 1 sec.) with amplitude of -35 dBm. Each pulse is captured with correct amplitude.

POI calculation depends on FFT rate, chosen RBW and adjusted Span. The principle of POI is described with a span of 40 MHz (=51,2 MSa/sec.) and RBW of 3.21 MHz (Kaiser Window) *in figure 10*. Due to calculation time, second FFT acquisition starts after 6.82  $\mu$ sec. Window size is depending of RBW in real time mode:

$$T_{Window} = \frac{1}{RBW}$$

Start position of first FFT acquisition and End position of second FFT acquisition defines POI time value

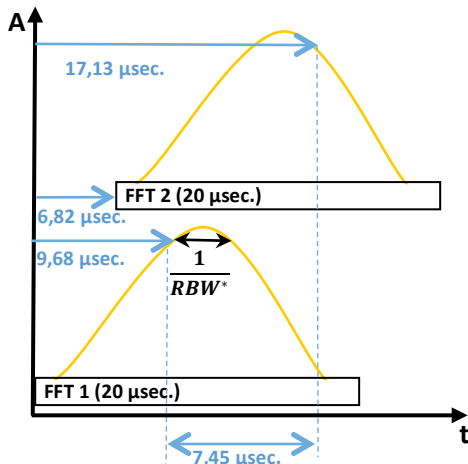

Figure 8: Example with RT-Span of 40 MHz, sample rate of 51.2 MSa/s and RBW of 3.21 MHz (Kaiser Filter)

POI can also be calculated as follow:

$$T_{POI} = \frac{(N_{Window} + N_{Fix} - 1) - N_{Overlap}}{Sample\ rate} = \frac{(32 + 1024 - 1) - 674}{51,2 \frac{MSa}{sec.}} = 7,45 \mu sec.$$

With that POI and speed it is now possible to measure a Bluetooth signal with the RT-SA mode of RSA5000 series. Usage of maximum hold is no longer needed. It is possible to set 6 different RBW settings in RT-SA mode and speed is not affected.

### Real-time Visualization:

Since Real-time analysis adds the dimension of time to the acquisition the user can choose from multiple rich data views helping to quickly debug their designs

- Normal Trace Analysis
- Density Analysis
- Spectrogram
- Power vs Time

In **Normal Mode** the trace information of current time is visible. It looks like a trace of a SA but due to the real time sweep more information is visible at the same time compare to SA. Normal trace analysis is a 2D measurement (power over frequency).

### Normal Mode Display

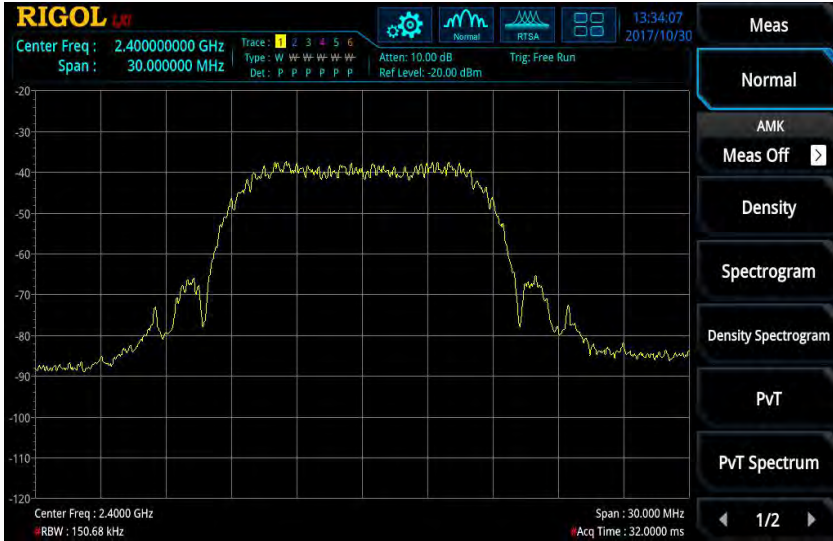

With **Density Analysis** it is possible to analyze the repetition rate of a signal. Density Mode puts data into a color map based on the probability of that frequency (from blue = 0% to red = 100%, *see figure 8*). As more often the signal hits a single pixel point (power vs frequency) within a certain time it increases the probability and changes the color of this pixel. For example a constant wave [CW] signal would be visible in red color. A very short single signal event would be visible in blue color. The color percentage can be calculated as follow:

$$n = \frac{T_{hits}}{T_{acquire}} * 100\%$$

Density View is particularly useful for identifying superimposed signals and separating signals that share the same frequency and for seeing time varying and frequency hopping signals.

## Density Mode Display

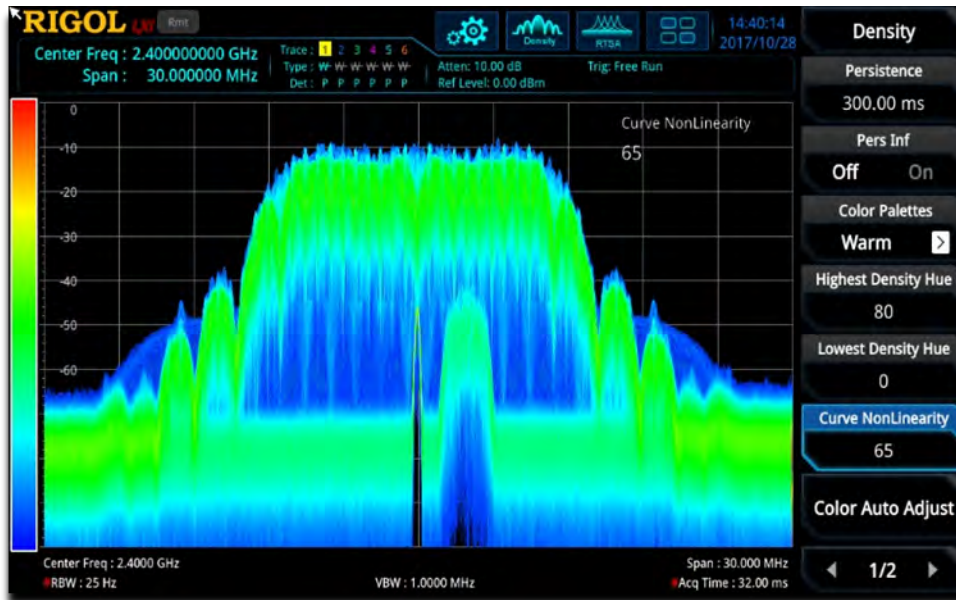

In normal and density mode it is possible to activate a **Spectrogram** measurement. Spectrogram is a waterfall displaying frequency over time allowing users to measure out duration of pulses (like for Bluetooth signals), to clearly view frequency changes over time and to identify interference. A spectrogram also works with a color scheme for signal level (DANL: 0% = blue, Reference level: 100% = red). Density in combination with spectrogram is a 4D measurement (power over frequency over repetition rate and power over time, *see figure 12* with a Bluetooth example).



## Spectrogram Display



Figure 9: Bluetooth signal measured with density spectrogram

In **Power vs Time (PvT)** mode it is possible to display the time domain of a signal within adjusted real time bandwidth. The acquisition time can be changed in this measurement. The Power vs Time analysis is displayed for the used real time bandwidth and not to RBW like in SA with zero-span configuration. Signal bursts of modulated signals and pulses can be displayed to measure duty cycle and amplitude of a pulse or to display pulse trains over certain time. PvT can be used in combination of normal trace analysis (frequency spectrum) and spectrogram (*see figure 13*).

Comparing the measurement result of Bluetooth signal in *figure 12* and *figure 13* and the result of traditional swept spectrum analyzer (*figure 2*) shows the engineer has much more information available with Real-time. Within the adjusted real time bandwidth all frequency components can be measured. Time information can be displayed in parallel of spectrum measurement, it is visible that this signal is a frequency hopping spread spectrum signal and the length of data block can be analyzed. The Power vs Time is no longer depended on RBW bandwidth like in SA and frequency domain and time domain can be displayed in one time.

### PvT Display

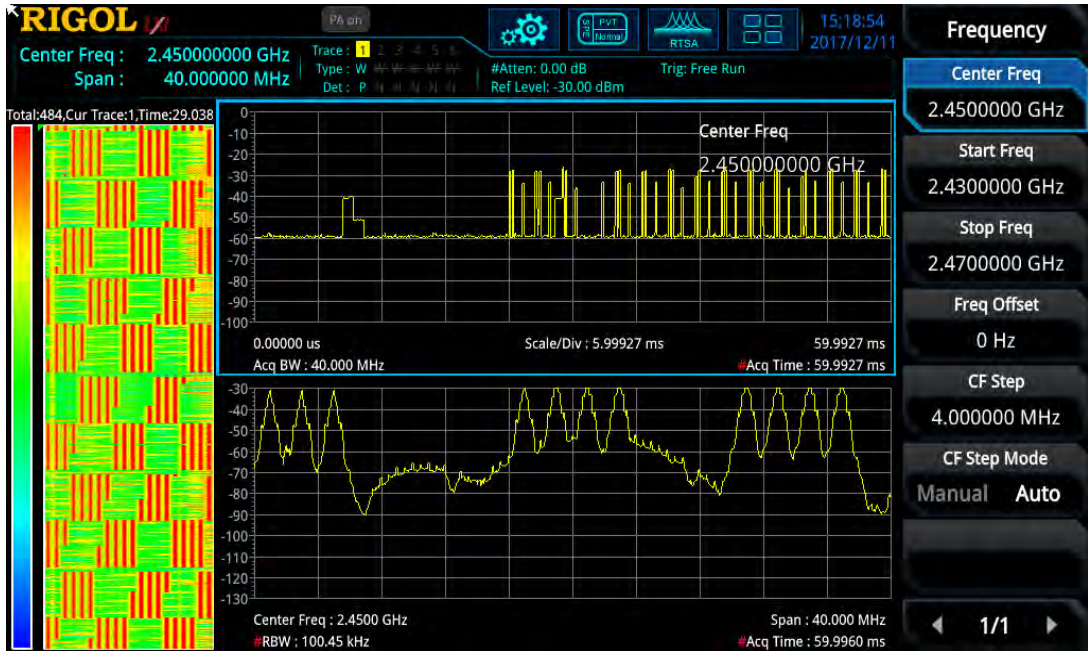

Figure 10: normal trace vs spectrogram vs PvT of a Bluetooth signal

## Chapter 5: Common Component Tests

Now that we have a basic understanding of the instrumentation used for measuring RF, let's take a closer look at measuring the performance of some common RF components using a spectrum analyzer.

### The Tracking Generator

Many component-level tests require an RF source to deliver a signal to the device-under-test (DUT) with a known amplitude and frequency. When testing an RF filter, for example, the idea would be to deliver a series of known amplitudes at specific frequencies to see where the filter is most effective. It would be possible to synchronize an external RF source with the sweep of a spectrum analyzer to perform this test, but many spectrum analyzers are available with a tracking generator that can simplify this type of testing.

A tracking generator is an extension of the sweep circuit. It is a programmable RF source with the ability to synchronize the output frequency with the sweep steps of the spectrum analyzer. In this way, the source and measurement frequencies are locked. If measuring from 1MHz to 100MHz on the spectrum analyzer, the tracking generator outputs a continuous sine wave with a frequency that will sweep from 1MHz to 100MHz in full synchronization with the measurement.

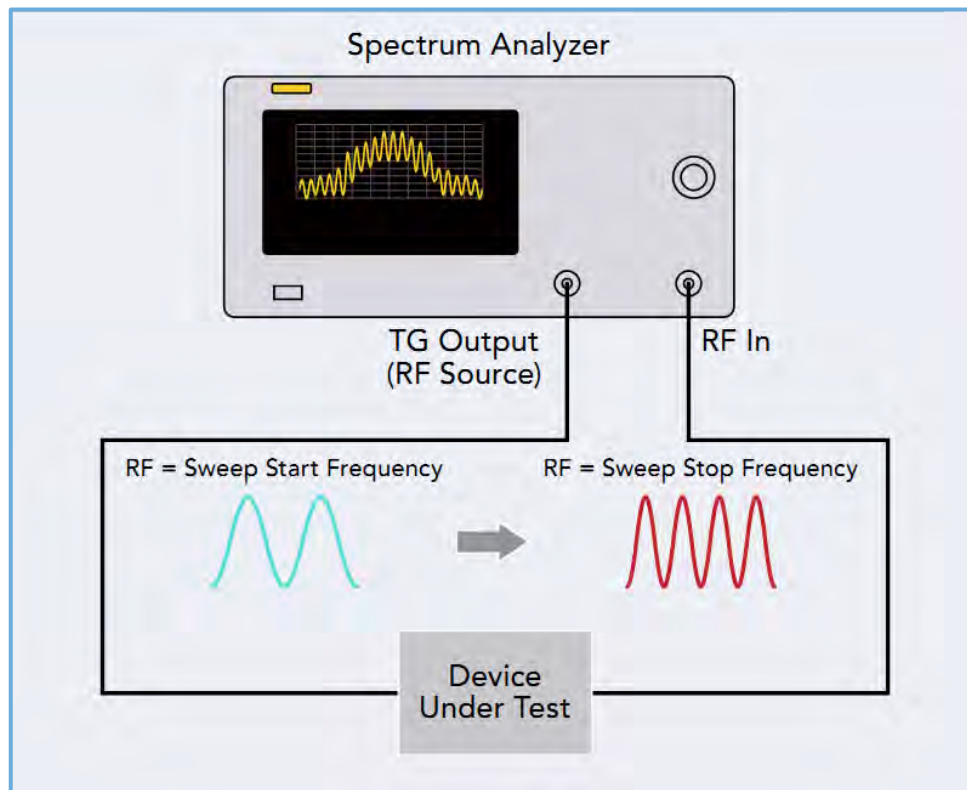

Figure 4-1: Example of a spectrum analyzer with tracking generator sweeping a DUT.

## Testing Filters

A filter is a useful component in many designs. The primary goals of a filter are to remove unwanted frequencies and to enhance desired frequencies from an input signal.

Here are some commonly used filters:

*Low pass:* Allows frequencies lower than a certain value to pass through, and rejects higher frequencies. This can be used to remove high frequency noise from a signal.

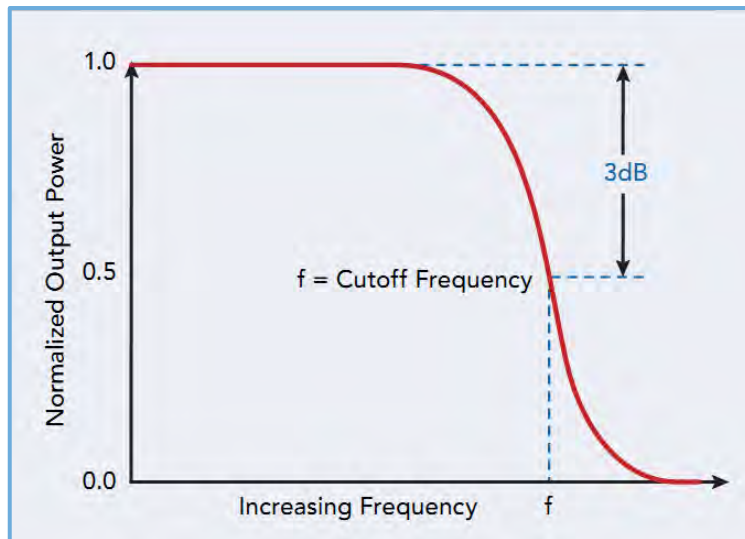

*High pass:* Allows frequencies higher than a certain value to pass through, and rejects lower frequencies. This can be used to remove low frequency components from the input signal.



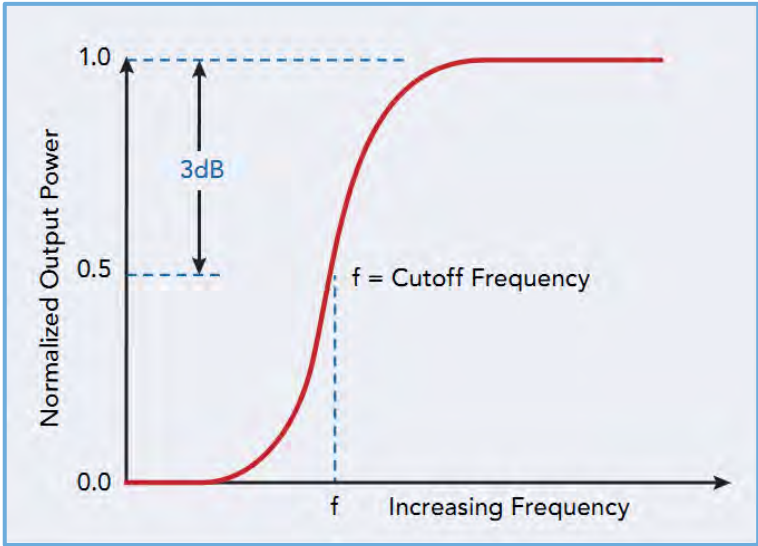

**Bandpass:** Allows a certain frequency range, or band, to pass through the filter and rejects those frequencies that are outside of the operating frequency band. This type of filter will allow a band of frequencies to pass through the filter with little to no changes while drastically lessening the amplitude of signals having frequencies outside of the operating band.

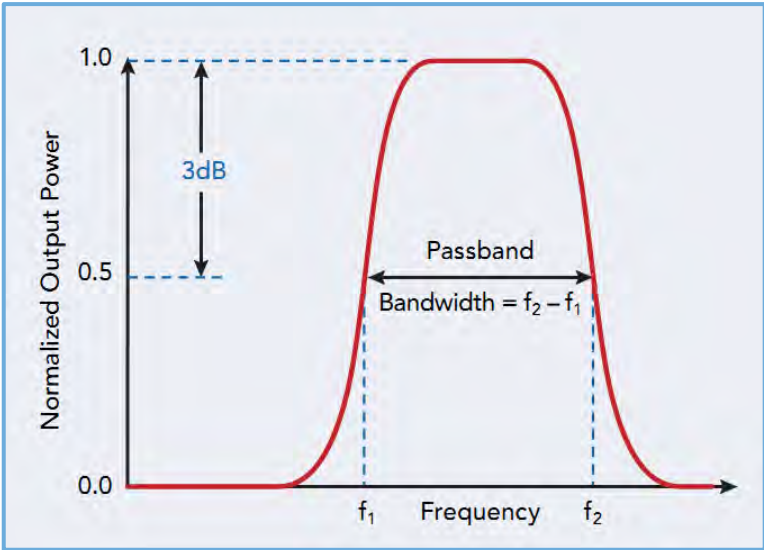

**Notch:** Rejects those frequencies that are inside of the operating frequency band and rejects those within the operating band of the filter. This type of filter will allow all frequencies outside of the operating band to pass through the filter with little to no changes while drastically lessening the amplitude of



signals having frequencies inside of the operating band. This is the exact opposite of a bandpass filter.

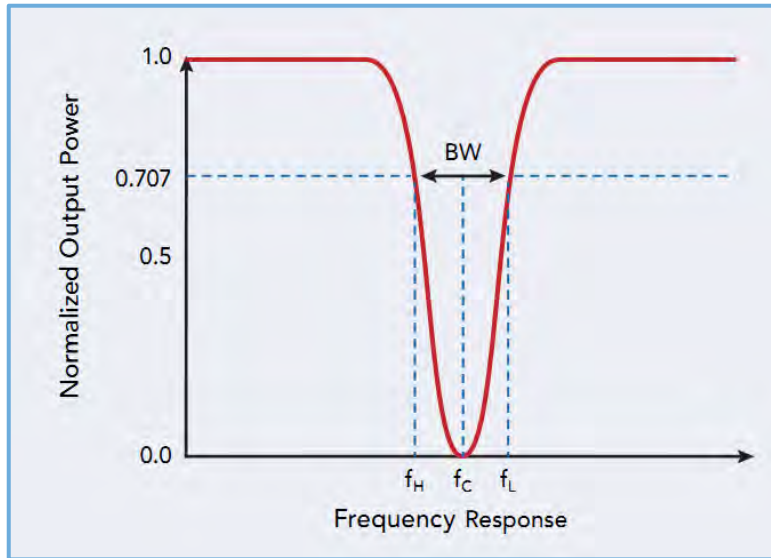

In all cases, testing a filter provides information about its quality, such as how well it decreases unwanted signals and how well it allows wanted signals through.

Testing a filter using a spectrum analyzer has a number of common steps.

#### Required Hardware:

- Spectrum analyzer with tracking generator
- Cabling and adapters to connect to the filter
- Filter to test

#### Test Steps:

- Normalize the trace (optional)

Many elements in an RF signal path can have nonlinear characteristics. In many cases, these nonlinear effects on the base measurements can be minimized by normalizing the instrument. Normalization is the process of mathematically removing the effects of cabling, adapters, and connections that could add unnecessary error to the characterization of the filter.

1. Connect the tracking generator output to the RF input using the same cabling that will be used to test the device. Any element, like an adapter, used during normalization should also be used during device measurement because any changes to the RF signal path could affect the accuracy of the measurement.

**NOTE:** Clean the surfaces of the adapters and input with a lint-free cloth or swab and electronics contact cleaner to prevent damage and ensure repeatability.

2. Enable the tracking generator.
3. Store the reference trace.
4. Enable the normalization. Now, the displayed trace will more accurately represent the filter by removing cable and adapter losses.

- Measure the filter

1. Connect the tracking generator output to the filter input using the appropriate cabling and connectors.
2. Connect the filter output to the instrument RF input.

**NOTE:** Clean the surfaces of the adapters and input with a lint-free cloth or swab and electronics contact cleaner to prevent damage and ensure repeatability.



**Figure 4-2:** Front panel of a spectrum analyzer equipped with a tracking generator. This view shows connections to the RF output of the tracking generator and the RF input of the analyzer.

3. Configure the stop, start frequency for the span of interest.
4. Set the tracking generator amplitude.

**NOTE:** If the instrument is equipped with a preamplifier, enabling it can lower the displayed noise floor.

5. Enable the tracking generator. Note the small bump in **Figure 4-3**.

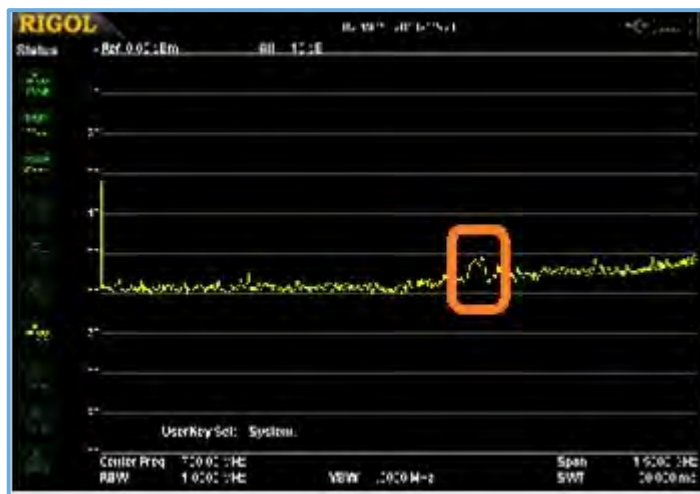

Figure 4-3: A bandpass filter trace.

Adjust the amplitude, start, and stop frequency to zoom in on the trace.

Some analyzers have a convenient auto-scale feature that can automatically configure the analyzer to display a full view of the area of interest on the trace.

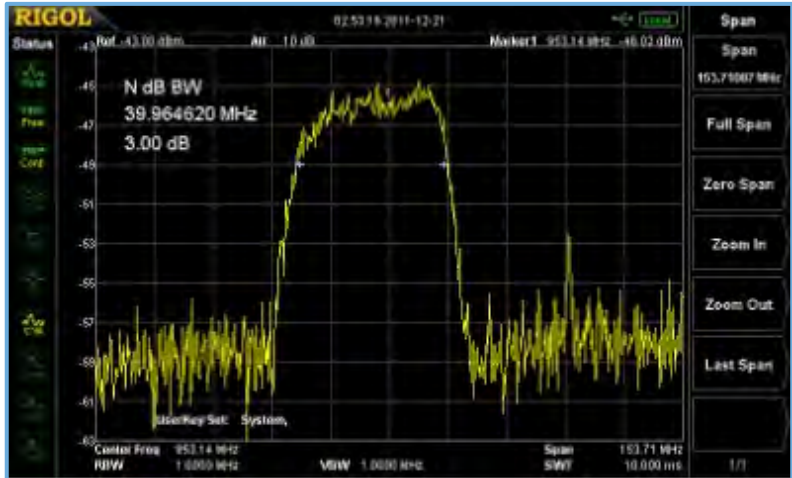

Figure 4-4: After Auto.

**NOTE:** Some analyzers also have markers. These are cursors that can show the frequency and amplitude of specific points on the trace, as well as the ability to measure bandwidth at a particular dB level.

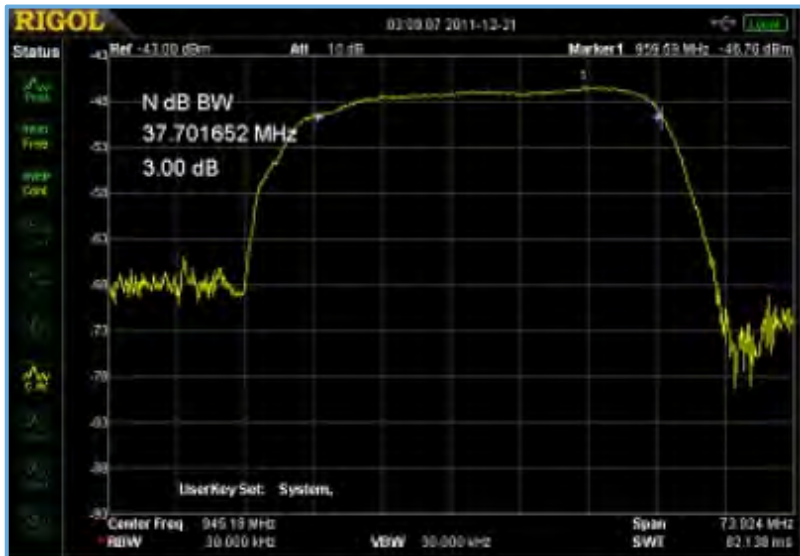

Figure 4-5: 3dB bandwidth measurement of a bandpass filter.

## Cable/Connector Loss

Cables and connectors can have a dramatic effect on the accuracy and validity of measurements on additional components. They also wear with time and use. This wear can show up as an increase in attenuation over particular frequency ranges.

A spectrum analyzer and a tracking generator allow testing the insertion loss (loss vs. frequency) of the cables and adapters easily.

### Required Hardware:

- Two N-type to BNC adapters (**Figure 4-6**). Select adapters that convert N-type (in/out connectors on most spectrum analyzers) to the cable type being tested. Also note that higher quality connectors (silver-plated, beryllium copper pins, etc.) equal better longevity and repeatability.



**Figure 4-6: N-type to BNC adapter.**

- A short reference cable with terminations that match the adapters being used and the cable-under-test.
- An adapter to go between the reference cable and the cable-under-test. This experiment will use a BNC “barrel connector” (**Figure 4-7**). Note that higher quality connectors (silver-plated, beryllium copper pins, etc.) equal better longevity and repeatability.



**Figure 4-7: BNC barrel adapter.**



- Alternately, use two adapters and a short cable as a reference assembly to normalize the display before making cable measurements. This removes the need to have the cable-to-cable adapter.
- A spectrum analyzer with tracking generator (TG).

Test Steps:

1. Attach the adapters to the tracking generator (TG) output and RF input.

**NOTE:** Clean the surfaces of the adapters and input with a lint-free cloth or swab and electronics contact cleaner to prevent damage and ensure repeatability.

2. Connect the reference cable to the TG out and RF In on the analyzer.



Figure 4-8: Measuring the reference cable.

3. Adjust the span of the scan for the frequency range of interest.
4. Adjust the tracking generator output amplitude and spectrum analyzer display to view the entire trace.
5. Enable the tracking generator output.

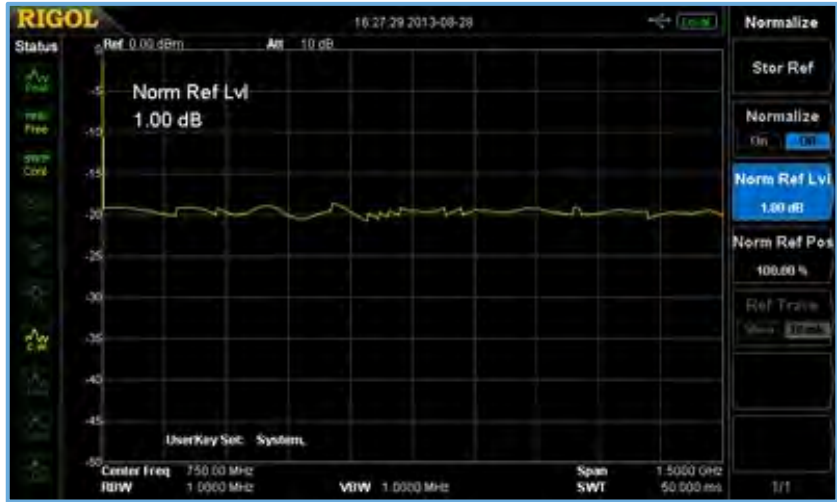

Figure 4-9: Reference cable insertion loss before normalization.

6. Normalize the reference insertion loss. This mathematically subtracts a reference signal (stored automatically) from the input signal.

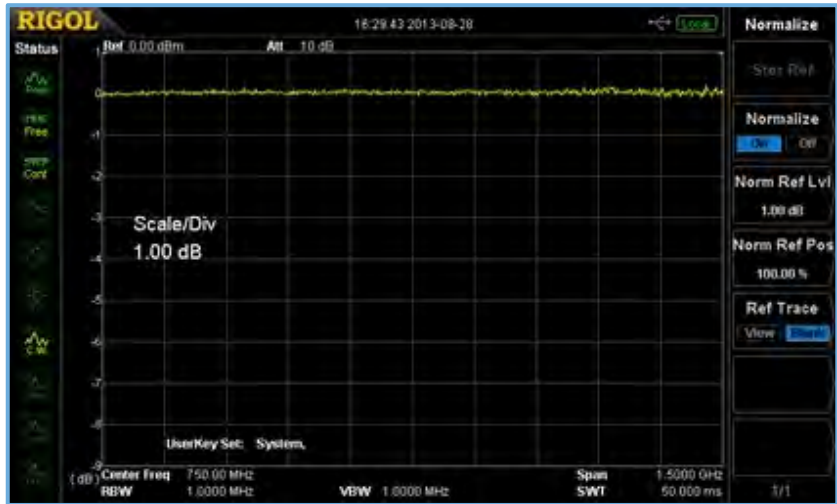

Figure 4-10: Reference cable insertion loss after normalization.

7. Disconnect the reference cable from the RF input. Place cable-to-cable adapter (BNC barrel or other) and connect to the cable to test.
8. Connect the cable-under-test to test to RF input and enable the tracking generator.



Figure 4-11: Cable-under-test connected.

The screen displays the cable-under-test losses plus the error of the cable-to-cable adapter.

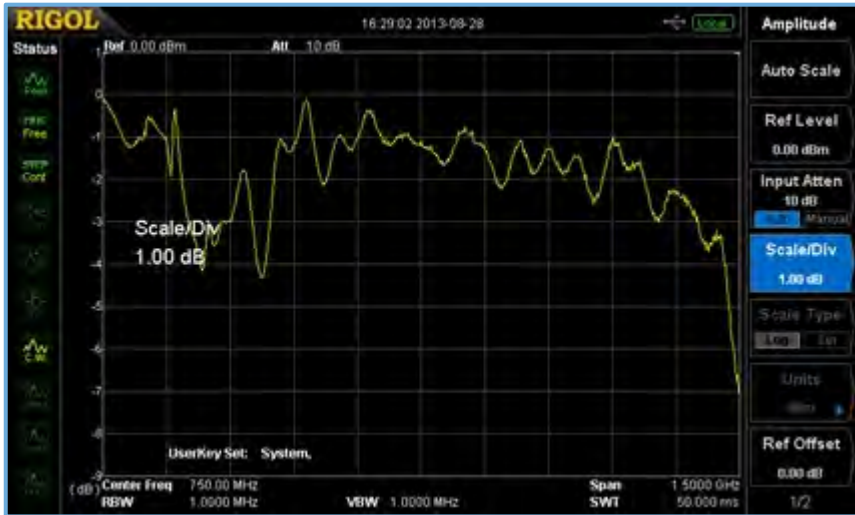

Figure 4-12: Zoomed view of cable-under-test loss vs. frequency.

## VSWR of an Antenna

As described previously, electromagnetic radiation can be described using terms and concepts from wave theory. Electromagnetic waves add, cancel, and reflect much like waves on water.

Imagine a small wave in a bucket of water. When the wave hits the inside wall of the bucket, a portion of the wave is reflected back into the center of the bucket and interacts with other reflected waves as it travels back-and-forth along the surface of the water. The wave direction and velocity change when the wave interacts with the bucket because there is a density difference between the water and the bucket. A similar situation occurs with electromagnetic waves.

With the bucket analogy, the water and bucket have different densities. This difference affects the speed of the wave and causes a portion of the incoming, or incident, wave to be reflected directly opposite to the original path of motion. As the waves travel back-and-forth across the surface, they will add and subtract depending on their relative phases.

When an electromagnetic wave travels from one material to another, it can also undergo reflection. When an electromagnetic wave encounters a material with a different impedance, some or all of the wave can be reflected. If the impedance of the new material is much greater than the original impedance, a large amount of the original wave can be reflected. Large amounts of reflected energy can be inefficient and could cause damage to sensitive components in the circuit.

The Voltage Standing Wave Ratio (VSWR) is a measurement that can be used to judge the quality of the impedance matching for cables and other passive devices. It is also mainly used to determine the efficiency of antennas to radiate power.

A perfectly matched antenna/cable system will have a VSWR of 1. In reality, the best systems will have VSWR values of 1.1 or 1.2.

Higher VSWRs indicate a greater degree of impedance mismatch. For antenna users, this indicates that more of the original signal is reflected back towards the transmitter and it indicates a system that has low efficiency.

## Required Hardware:

A spectrum analyzer with a tracking generator, such as the Rigol DSA815-TG

- Coaxial Directional Coupler or VSWR Bridge with an impedance match for the component being tested. This is typically 50Ω for most antenna and RF networks.
- An antenna or other component to test
- Impedance-matched coaxial cable to connect the coupler to the tracking generator. Depending on the Directional Coupler design, you may need another cable or adapter to connect it to the DSA.



Figure 4-13: A Rigol VB1032 VSWR bridge.

## Test Steps:

1. Clean all connectors with a lint-free cloth or swab and electronics contact cleaner. Make sure to remove any contamination, dirt, or metallic flakes in and around mating surfaces.
2. Connect the RF coupler coupled (CPL) connection to the RF input of the DSA.
3. Connect the cable from the TG output on the front panel of the DSA to the output (OUT) of the coupler.

**NOTE:** Leave the input (IN) of the coupler open. This will provide 100% reflection and be used to minimize the effects of the cabling, adapters, and coupler.



4. Configure the DSA frequency span for the DUT. Correct for the cabling, adapters, and coupler effects by storing the open circuit (no DUT = Max Reflection) conditions by normalizing the current setup. Enable the tracking generator.
5. Connect the DUT of interest to the coupler input (IN).
6. If the analyzer is equipped with markers, select a marker to identify your location on the trace.



The minimum value displayed on the DSA is the return loss of the DUT. Record this value in dB.

**Calculations:** The VSWR can be calculated by the following

$$a = \text{Return Loss (dB)}$$

$$r = \text{Reflection coefficient of the DUT}$$

$$s = \text{VSWR}$$

$$r = 10^{(-0.05 * a)}$$

$$s = (1 + |r|) / (1 - |r|)$$

For example, if measuring an antenna with the following parameters:

$$a = -26.22 \text{ dB}$$

$$r = 10^{(-0.05 * 26.22)} = 10^{(-1.31)} = 0.05$$

The result is:

$$s = (1+0.05) / (1-0.05) = 1.11$$

## Chapter 6: Common Transmitter Tests

RF transmitters are classified as any device that intentionally sources signals in the RF band of the electromagnetic spectrum. The main role of the transmitter is to create a signal with specific characteristics (power, frequency, encoding/modulation) and deliver it to a receiver that can “read” the signal. Most transmitters are wireless in nature. AM/FM radio stations, Bluetooth, and WiFi hot spots are examples of wireless transmitters that use air as a transmission medium. But some RF can be transmitted by wire: cable television (CATV) is the most widely used wired RF transmitter application.

Whether wireless or wired, the main requirements remain the same. The transmitted signal must have the proper amplitude in the proper frequency band to be picked up by the receiver. Measuring transmitters is common practice throughout the design process and is also used to monitor existing transmitters to ensure that the signals remain in their specific operating bands. For example, AM and FM radio stations commonly monitor their transmitters to ensure that they are operating within their licensed frequency band.

This section will describe some common tests that can be used to verify transmitter performance, then build on those ideas by citing some specific tests used within a specific transmission type.

### Output Power

The strength of an RF transmission can be affected by many outside factors. Imagine all the different materials that an FM radio transmission will encounter as the signal leaves the radio station antenna and arrives at a receiver. The signal may have to pass through glass, drywall, furniture, trees, and even people before it reaches its intended target. Even weather conditions, like air density, humidity, and storms, can affect the transmission. By measuring the output power, it’s possible to verify the signal is present and has enough power to be picked up at the receiver.

The output power is simply a measure of the transmitted signal’s strength. Measuring the output power directly at the transmitter allows verifying if the transmitter is working correctly. If all is well, it’s time to move down the transmission path and perform remote measurements at a distance from the transmitter, using antennas in place of the cable from the transmitter to the measurement instrument.

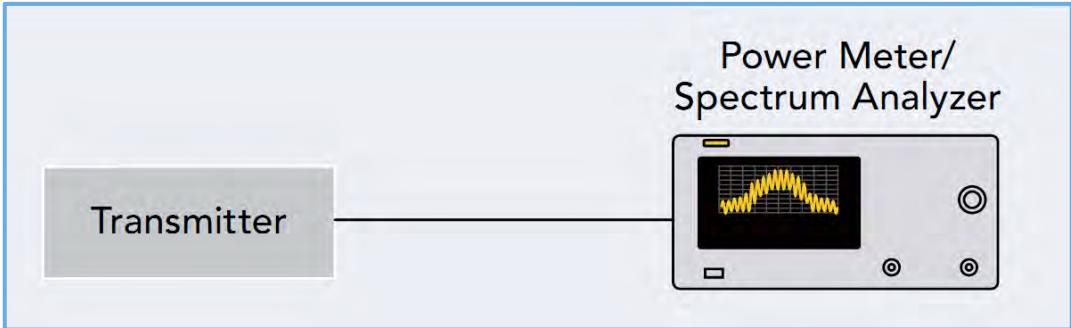

Figure 5-1: Transmitter direct output measurement using a cable and measurement instrument.

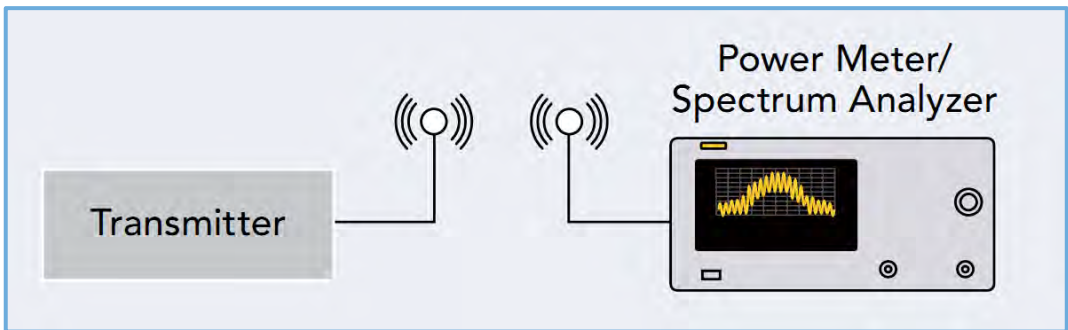

Figure 5-2: Transmitter remote output measurement using antennas and a measurement instrument.

A simple power measurement can be performed using a dedicated RF power meter or a spectrum analyzer. Although power meters tend to be more accurate, they often have a longer measurement time than spectrum analyzers.

### Transmission Band

The transmission frequency is another important measurement that must be performed to characterize a transmitter. Testing the frequency band means directly measuring the frequency (or frequencies, in some cases) that a signal is occupying in the RF spectrum. It's important to be sure that the transmission signal has the proper frequency to be detected by the receiver and that the signal is not interfering in frequency bands near the desired frequency.

Signals that bleed into or occupy adjacent bands can cause interference and disturb the reception of the signals that are supposed to be occupying that band.

## AM Transmission Test

Amplitude modulation (AM) is a common method of adding information to an RF signal. The amplitude of the carrier waveform changes proportionally to the input signal. AM is typically used to transmit voice information and was the primary modulation scheme for initial research in radio communications in the early twentieth century.

In the time domain, a typical AM signal will look something like **Figure 5-3**.

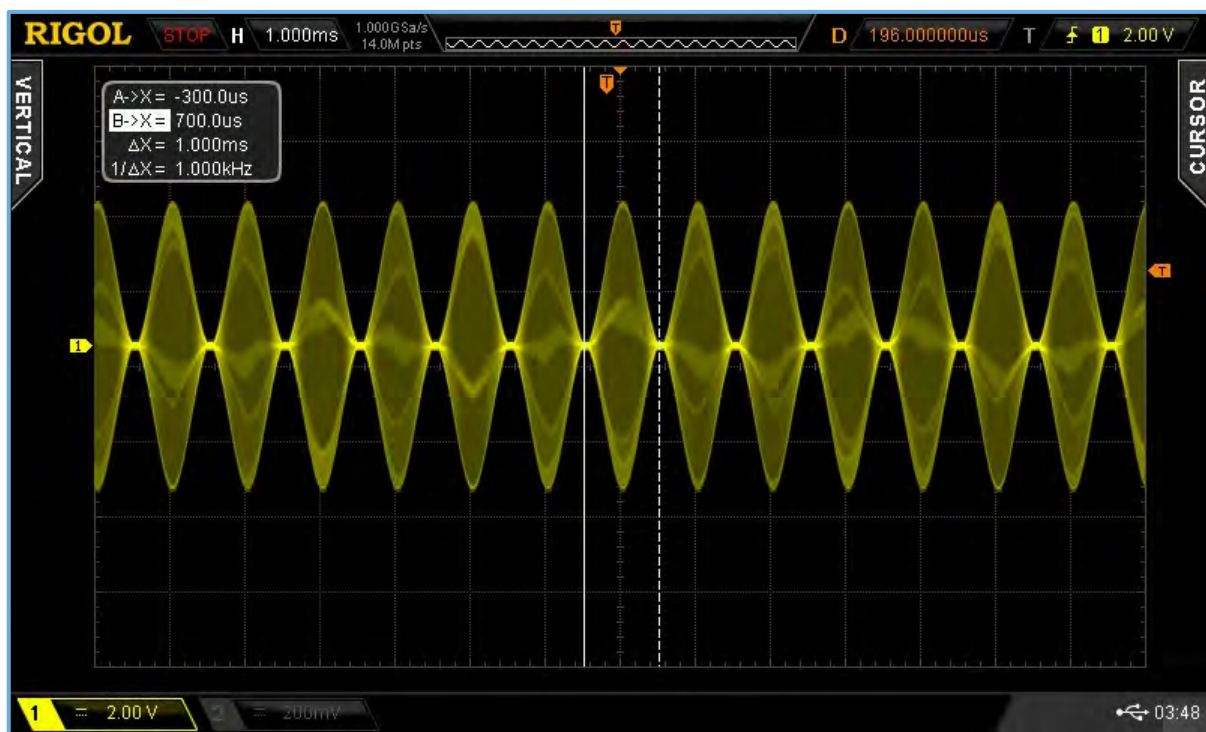

**Figure 5-3: 10MHz carrier, 1kHz modulation AM signal on a scope.**

In this case, the carrier signal has a frequency of 10MHz and the amplitude modulation is set to 1kHz. Note that the base period in the oscilloscope display in **Figure 5-3** shows periodic beats, or nulls, in the time-based waveform. These are areas where the carrier amplitude is near zero. Note that the beat frequency matches the amplitude modulation of 1kHz.





- An external attenuator (optional) may be required to limit the signal power that is directed to the analyzer.

### Test Steps:

1. Connect the transmitter to the cable/adapters or transmission antenna.  
**NOTE:** Clean the surfaces of the adapters and input with a lint-free cloth and an electronics contact cleaner to prevent damage and ensure repeatability.
2. Connect the other end of the cable/adapters or receiver antenna to the RF input of the spectrum analyzer.  
**NOTE:** If using an external attenuator, place it on the RF input of the analyzer.
3. Set the center frequency of the analyzer to the carrier frequency of the input signal. In the example in **Figure 5-5**, a 900MHz AM transmission is being monitored.
4. Set the analyzer frequency span to 10× the expected modulation frequency. In this example, the carrier is modulating at 1kHz, so the span should be set to 10kHz.
5. Set the resolution bandwidth (RBW) to a value less than the modulation frequency. In **Figure 5-5**, the RBW is set to 100Hz. If an RBW close to the modulation frequency is used, there might not be sufficient resolution to see the modulation.

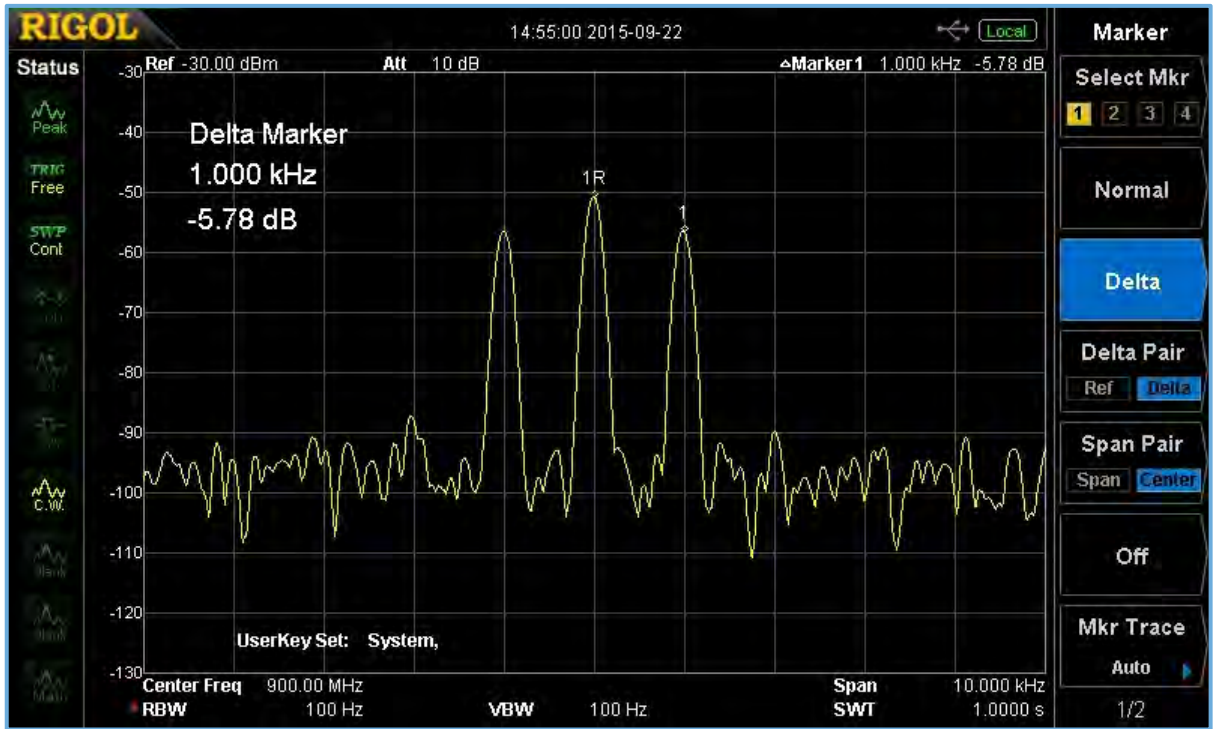

Figure 5-5: 10MHz carrier, 1kHz modulation AM signal on a spectrum analyzer.

Delta markers are enabled to show the frequency and amplitude differences between the carrier and modulation peaks. Note that the center peak matches the carrier frequency of 900MHz and the two additional peaks are 1kHz away from the carrier. It’s also possible to measure the power of the signal. In this case, the carrier is -50dBm.

The input signal in this case was modulated with a fixed 1kHz input. With an AM signal modulated by audio or voice information, the modulated peaks will actually vary with time. Many analyzers have a few features that can help with these real-world measurements.

If the instrument is so equipped, consider enabling the Max Hold trace type (Figure 5-6). Max Hold traces are similar to histograms. Each frequency bin value will only display the maximum value. This value will remain for successive scans until a greater value is measured for that frequency bin. This allows the analyzer to “build up” the full modulation envelope over a series of scans.

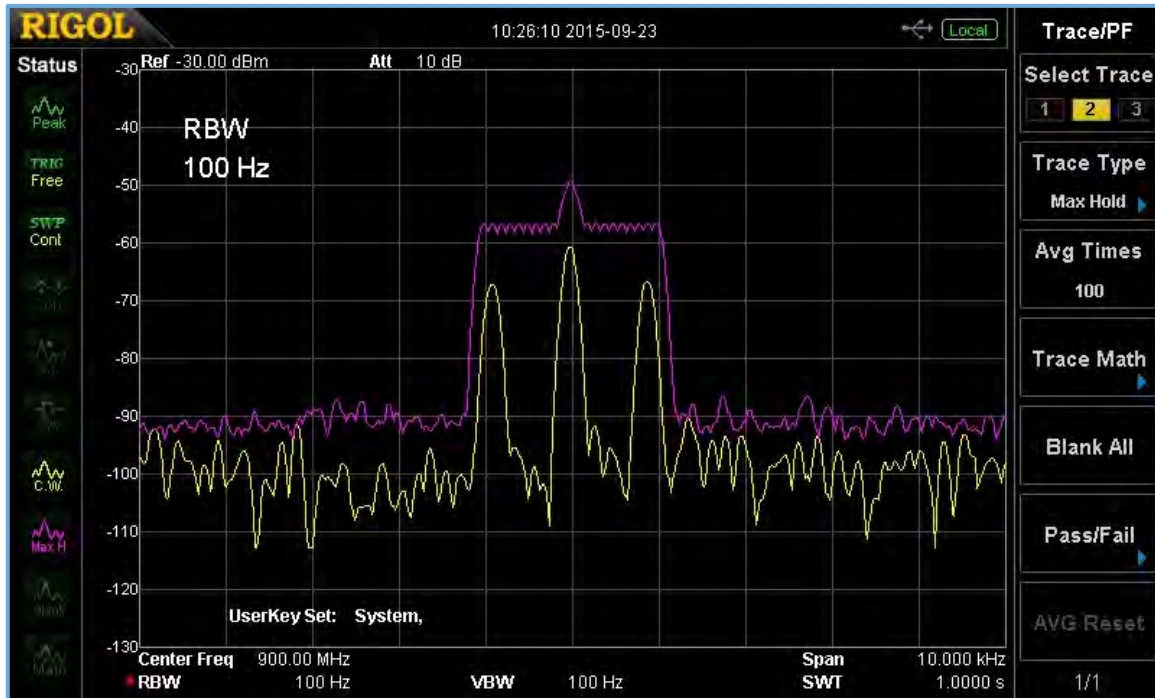

Figure 5-6: 10MHz carrier with varying modulation AM signal on a spectrum analyzer. The yellow trace is a “Clear Write” trace type. The pink trace is a “Max Hold” trace type that was built over successive scans.

If the spectrum analyzer is equipped with pass/fail masking, set up a limit mask to indicate quickly whether a particular signal is within the test limits, as shown in Figure 5-7:

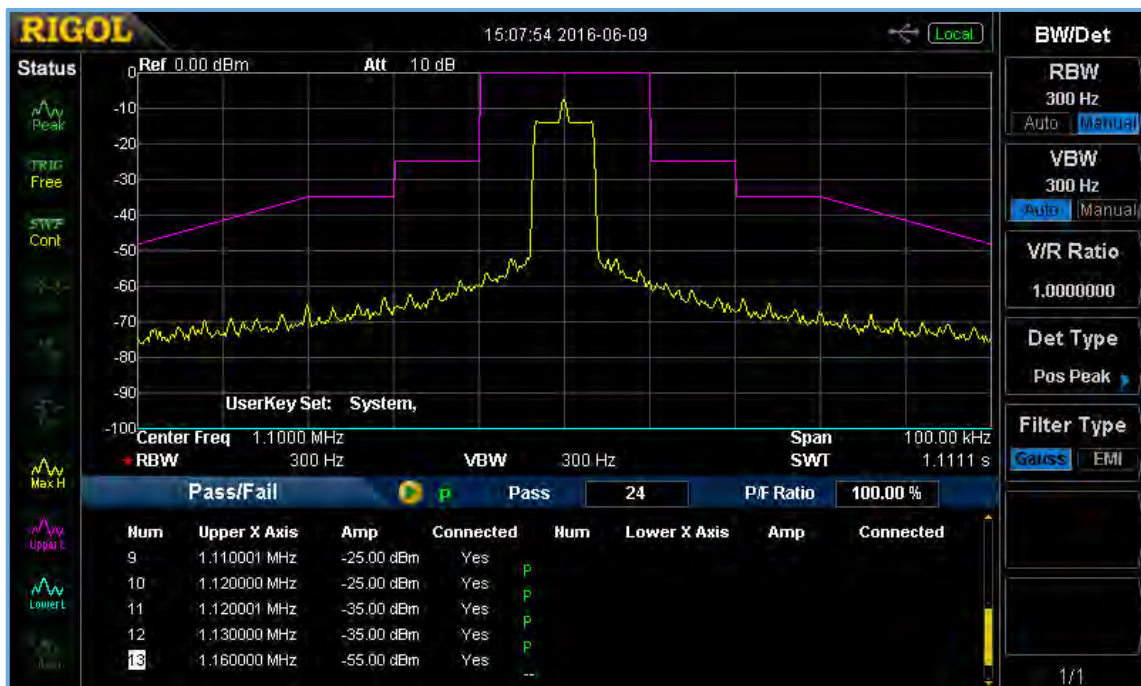

Figure 5-7: Spectrum analyzer showing a pass/fail mask on an AM Max Hold trace



## FM Deviation

Frequency modulation (FM) is another common method of adding information to an RF signal. The frequency of the carrier waveform changes proportionally to the input signal. FM is typically used to transmit voice information.

In the time domain, a typical FM signal will look like **Figure 5-8**:

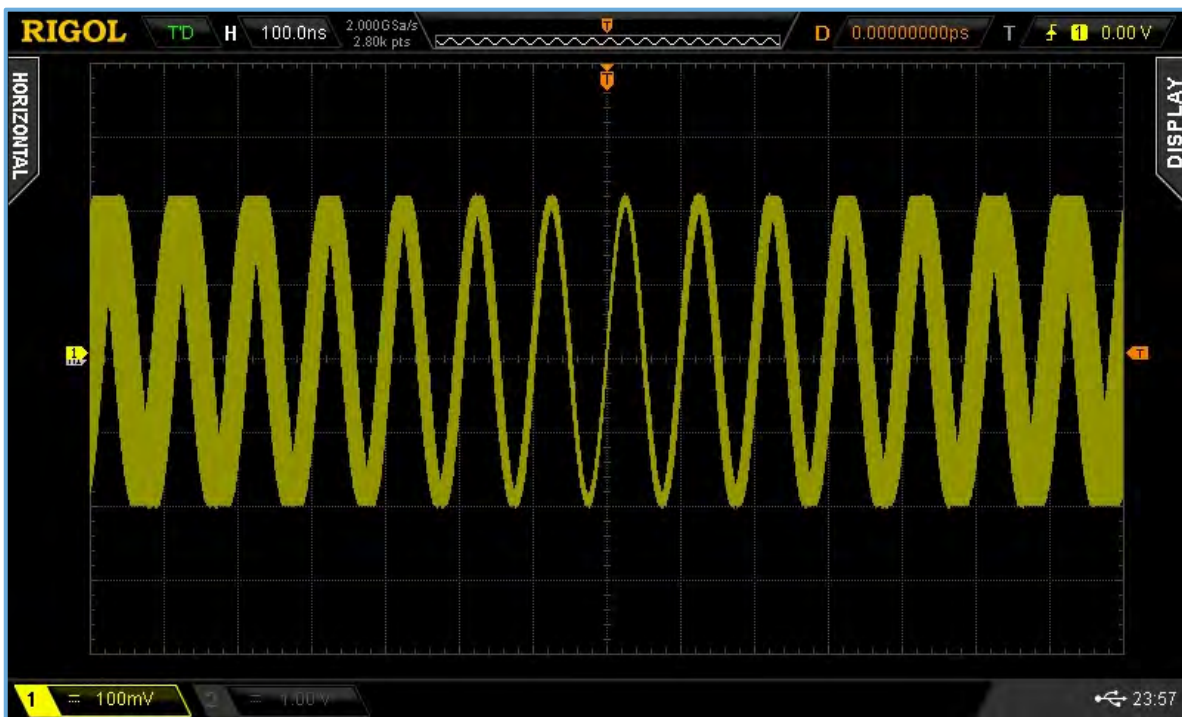

**Figure 5-8: 10MHz carrier, 1kHz modulation FM signal on a scope with persistence on to help show frequency modulations.**

In this case, the carrier signal has a frequency of 10MHz and the frequency modulation is set to 1kHz. Frequency modulation on an oscilloscope can be difficult to capture due to the triggering model most scopes use. In order to visualize the modulations of the frequency components of the incoming signal, it's necessary to lengthen the persistence time of the display. Persistence determines the length of time that a waveform is held on the display. Longer persistence times will hold waveforms on the display for a longer period of time and allow for a direct comparison of waveforms over a period of time. As shown in **Figure 5-8**, the frequency of the



sine wave is changing with time. This is shown by the wider waveform thickness near the edges of the displayed waveform.

Due to their constantly changing frequency, FM signals are difficult to analyze on an oscilloscope, even one with FFT analysis capabilities. Because a spectrum analyzer displays frequency information, it can be very handy.

Follow these steps to perform a basic FM transmitter test using a spectrum analyzer.

### Required Hardware:

- Spectrum analyzer
- Transmitter
- Cables, adapters, or antennas to connect to the transmitter and analyzer
- An external attenuator (optional) may be required to limit the signal power that is directed to the analyzer.

### Test Steps:

1. Connect the transmitter to the cable/adapters or transmission antenna.

**NOTE:** Clean the surfaces of the adapters and input with a lint-free cloth and electronics contact cleaner to prevent damage and ensure repeatability.

2. Connect the other end of the cable/adapters or receiver antenna to the RF input of the spectrum analyzer.

**NOTE:** If using an external attenuator, place it on the RF input of the analyzer.

3. Set the center frequency of the analyzer to the carrier frequency of the input signal. In the example in **Figure 5-9**, a 100MHz FM transmission is being monitored.
4. Set the analyzer frequency span to 10× the expected modulation frequency. In this example, the carrier is being modulated at 1kHz, so the span is set to 10kHz.

- Set the resolution bandwidth (RBW) to a value less than the modulation frequency. In the **Figure 5-9**, the RBW is set to 100Hz. If an RBW close to the modulation frequency is used, there might not be sufficient resolution to see the modulation.

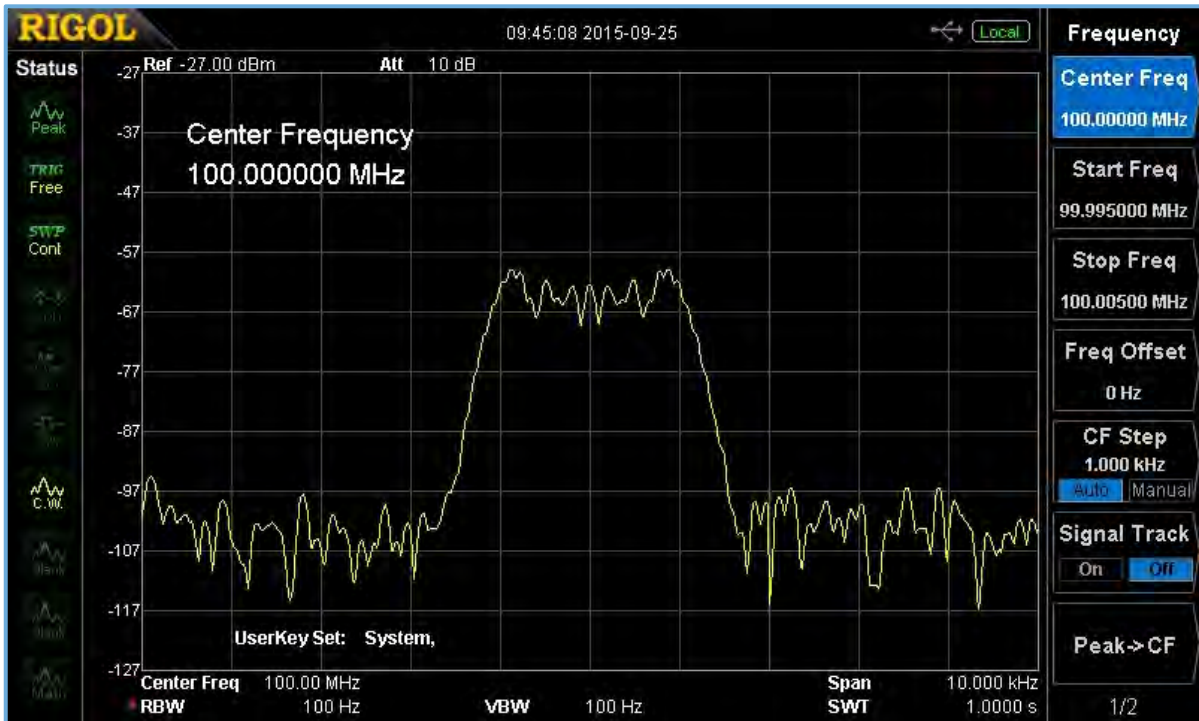

**Figure 5-9: 100MHz carrier, 1kHz modulation FM signal on a spectrum analyzer**

The input signal in **Figure 5-9** was modulated with a fixed 1kHz input. A real-world FM signal would be modulated by audio or voice information that could have a non-linear change in frequency. This would cause the frequency to vary with time. If the Max Hold trace type is available, it can be enabled, just as suggested with the AM signal. The FM Frequency Deviation of the signal can be measured in this way by collecting sweep data over a period of time.

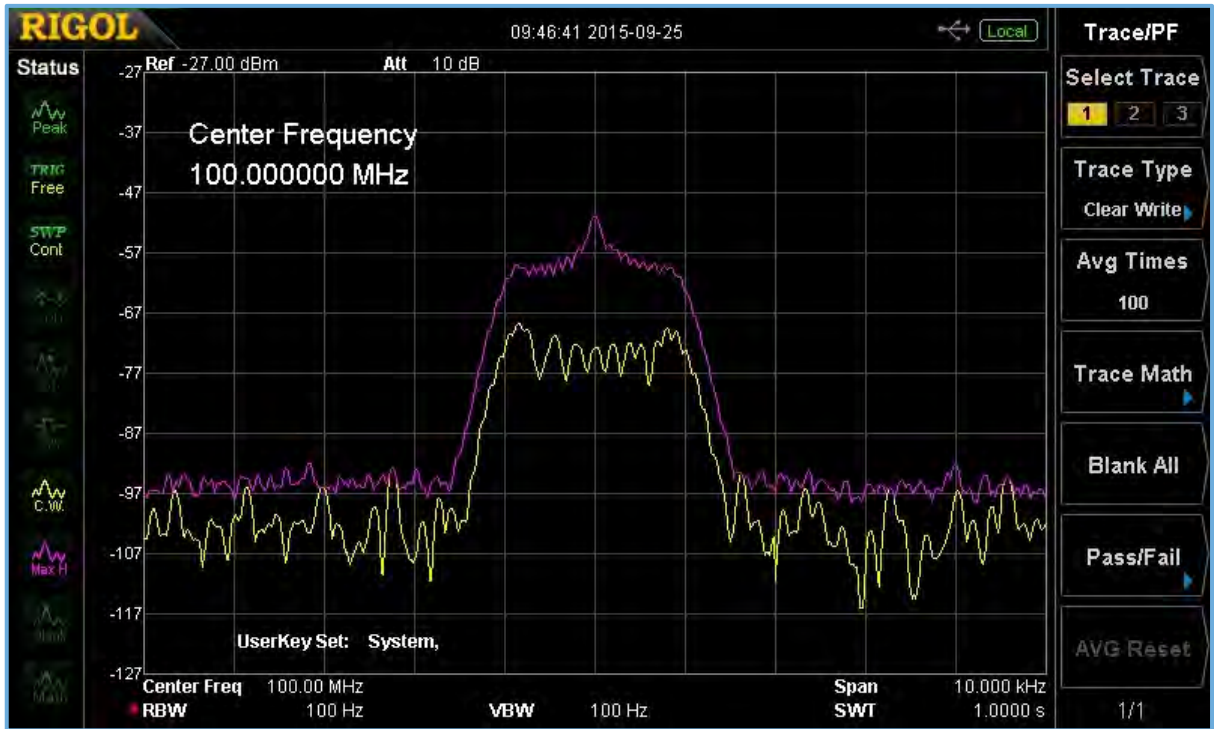

Figure 5-10: 100MHz carrier with varying modulation FM signal on a spectrum analyzer. The yellow trace is a “Clear Write” trace type. The pink trace is a “Max Hold” trace type that was built over successive scans.

FM deviation measurements are important because they allow visualizing the frequencies being used for transmission. If the deviation is too large, the transmission may interfere with nearby channels. By monitoring the transmission, adjustments can be made to maintain proper transmission characteristics and stay within the proper band.

### Harmonics and Spurs

An ideal transmitter would deliver the exact signal intended, with no additional unwanted components. Unfortunately, there are no ideal transmitters. In reality, a transmitter can have undesirable signal components like excessive harmonics and spurs. Luckily, there are a few ways to identify and minimize them.

Transmitters commonly use amplifiers to boost the signal strength. Unfortunately, most amplifier designs will add and amplify the harmonics of the output signal. Chapter 1 discussed superposition of sinusoidal waveforms and how harmonics of a sine wave can be built up to create different waveform shapes. A harmonic is simply a waveform with a frequency that is an integer value of the intended signals frequency. For example, for a sine

wave with a fundamental frequency of 10MHz, the 2<sup>nd</sup> harmonic is a 20MHz sine wave (Figure 5-11). The second harmonic is two times the fundamental frequency, the third is three times, etc.

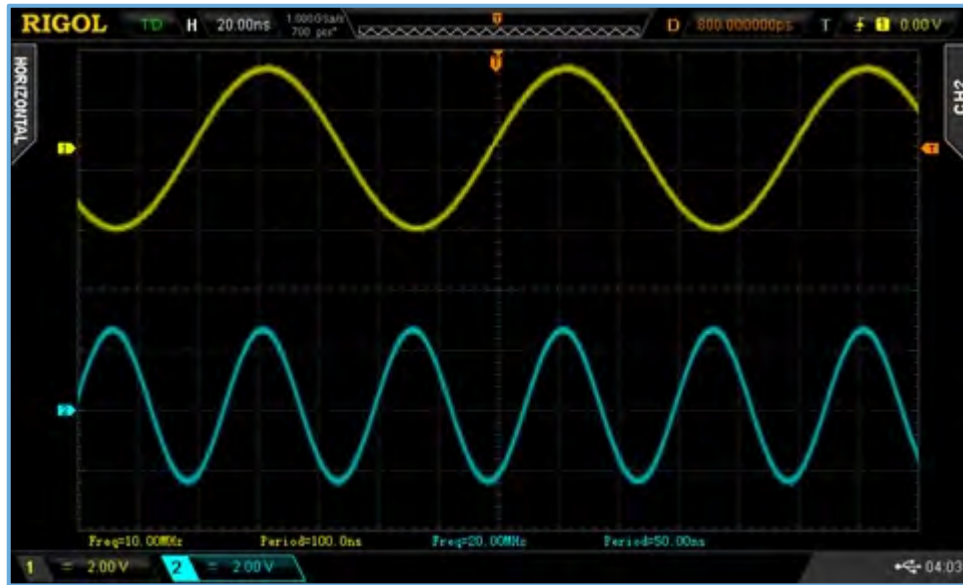
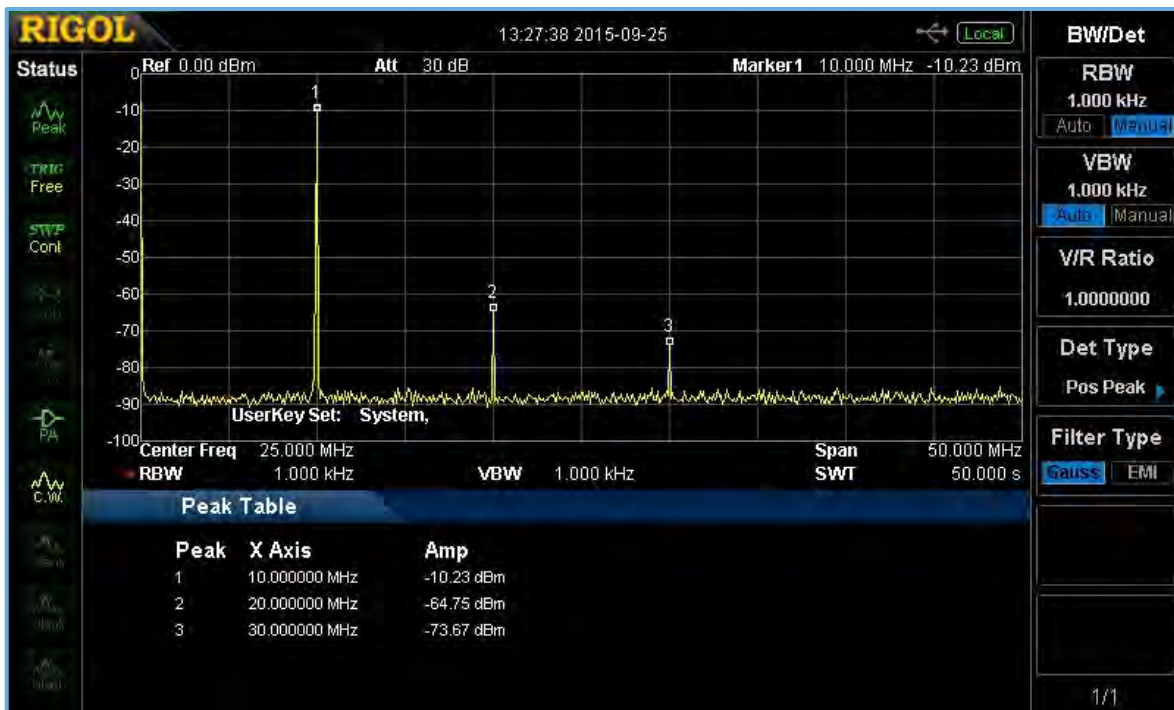

Figure 5-11: An oscilloscope displaying a sine wave with a frequency of 10MHz (yellow) and another sine wave with a frequency of 20MHz (light blue).

Figure 5-12 is a screen capture of a 10MHz sinewave from a high quality RF source.



**Figure 5-12: 10MHz sine input into a spectrum analyzer. Note 1<sup>st</sup> and 2<sup>nd</sup> harmonics.**

Note that the 2nd harmonic has a frequency that is twice the fundamental (20MHz) and the third peak is at 30MHz, or three times the fundamental. Even though the source was programmed to source an output at 10MHz, there are still some additional components to the output sinewave.

When searching for harmonics, it is important to widen the frequency span on the analyzer in order to capture them. If the fundamental frequency of the transmitter is 100MHz, it may be wise to look at a span from 100MHz to 500MHz or more, in order to capture a larger span of potential harmonics.

Harmonics also tend to be significantly lower in power than the fundamental frequency. Note how the power level drops significantly between the fundamental (-10dB) and the harmonics (-64dBm, -73dBm) in **Figure 5-12**. This can make them difficult to capture using an oscilloscope. Lowering the RBW value and using preamplification (if available) will lower the noise level of the analyzer and help to isolate these low powered signals.

If issues with excessive harmonics arise, note that many can be minimized by using filters or alternative transmitter designs.

Spurious emissions, or spurs, can also be problematic. A spur is typically the unwanted result of nonlinear components in a circuit or transmission path. Nonlinear components include amplifiers, mixers, and diodes, but they can also be created by oxide layers on the mating surfaces of cables and adapters.

Hunting for spurs is very similar to hunting for harmonics. Configure the spectrum analyzer span to cover a frequency range wide enough to cover the expected location of the spurs and lower the noise floor by using the RBW and preamplifier (if available). Unfortunately, spurs can be caused by different events. This leads to their location at unexpected frequencies, not even multiples of a fundamental like harmonics.

Many spurs are products of intentional or unintentional mixing of signals. Investigating areas where mixing products from known signals is a good starting spot. Chapter 3 addressed mixers and mixing products. In the simplest case, a mixer takes two signals as inputs and the resultant output contains the original signals, as well as the addition and subtraction of the inputs.



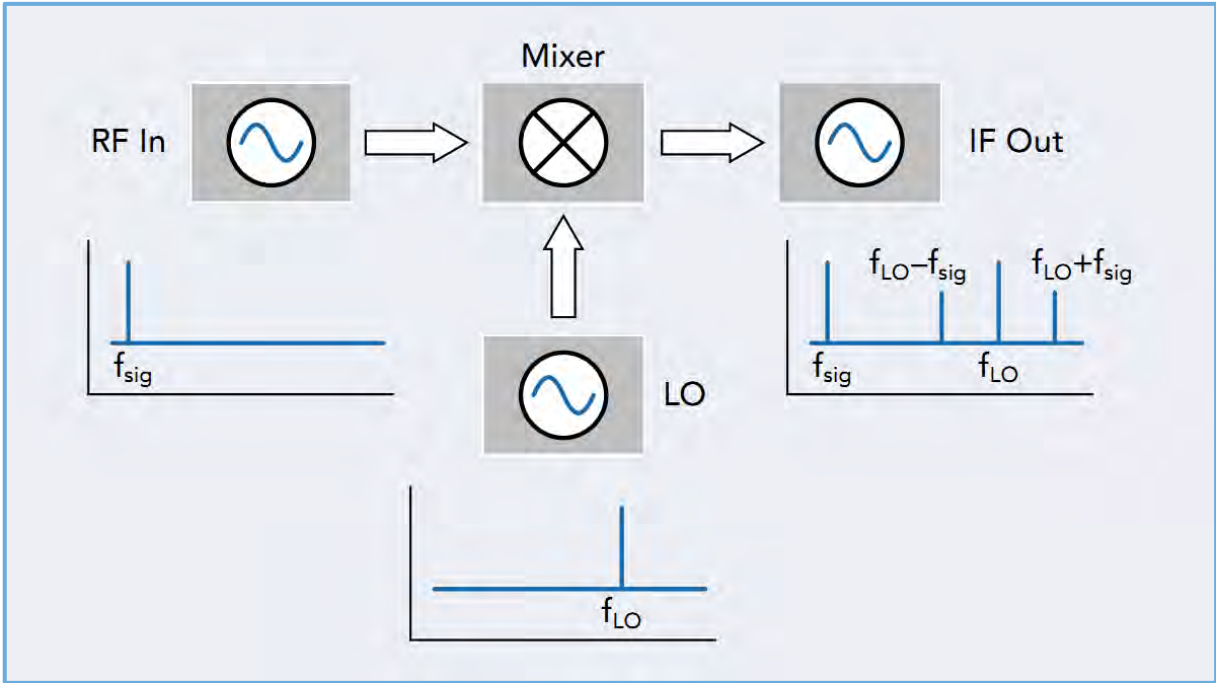

Figure 5-13: A simple mixer.

The best-case scenario is to identify the cause of the spurs and minimize the unwanted components by filtering, but investigation into connector torque (the “tightness” of a connection) and the cleanliness of physical connections can also be helpful.

## Chapter 7: Common Receiver Tests

An RF system's receiver is designed to collect an input signal at a specific frequency, filter out unwanted signals, and demodulate the input in a way that allows analyzing the base information. A typical example is the FM radio. Setting the channel on the radio dial is configuring the receiver to be more sensitive to the channel with that particular base frequency. It will then demodulate the audio information from the carrier, and play the audio through a speaker.

Receivers are available in both analog (AM/FM radio) and digital (WiFi, Bluetooth, Zigbee) types, but they all operate on similar base principles. **Figure 6-1** is a generic block diagram of a typical receiver.

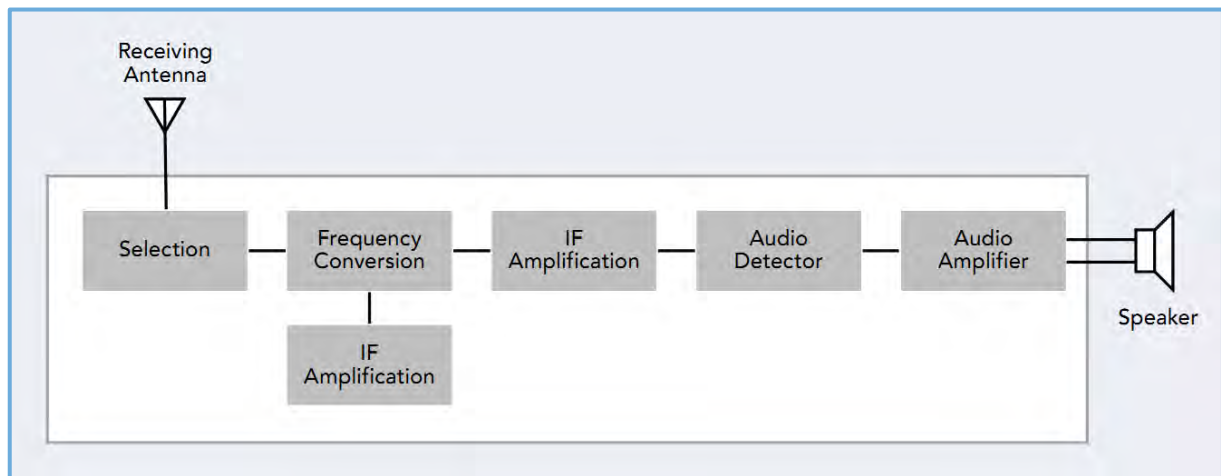

**Figure 6-1: Block diagram of a typical radio receiver. Note that other receiver types are similar in their block diagrams. The major differences are the demodulation (analog vs. digital) and output (speaker vs. data).**

This chapter provides a brief overview of each element in a typical audio receiver and presents some common test procedures for each, moving backward, starting at the speaker and ending with the antenna. In real life, it's possible to jump to test any section on its own, but this backward technique allows using the speaker to provide instant audible feedback when stepping through each design area.

Receivers typically contain filters and amplifiers that can also be tested individually using techniques presented in chapter 4. Review those sections for more specific tests on each component, if desired.

## The Speaker (Optional)

The speaker converts electrical signals to sound waves. The easiest method of testing a speaker is simply to connect a function generator to the speaker inputs. Function generators are instruments that can output voltages in specific waveform shapes like Sinusoidal, Square, and Ramp. They are typically low power (<1W), but they should have enough power to test the functionality of most simple speakers.

## Required Hardware:

- Function or arbitrary waveform generator like the Rigol DG1022 (**Figure 6-2**)
- Cabling to connect generator to the speaker. This is typically a BNC-to-alligator connection.



Figure 6-2: An arbitrary waveform function generator.

## Test Steps:

1. Study the schematics for the design. Clearly identify high voltages and ensure adequate shielding from any high voltage areas.
2. Disconnect the speaker wires from the receiver.
3. Check to make sure the speaker connections are clear of any contamination or dirt. Clean connectors with a cotton or lint-free swab and an electronics contact cleaner like DeoxIT® D5 if needed. Allow solvents to evaporate before turning on any electrical devices nearby.
4. Connect the function generator output to the speaker input wires.
5. On the generator, set the waveform to Sine, the frequency to 1kHz, and the amplitude to 1V (peak-to-peak) and listen for sounds from the speaker.
6. OPTIONAL: Adjust the frequency and voltage of the generator to test the frequency response and volume of the speaker. Humans can typically hear frequencies from 20Hz up to 20kHz.

A properly working speaker should have a noticeable change in output sound when the frequency and amplitude of the input signal are adjusted. If the speaker does not have sound output, it may need to be replaced.

## Audio Amplifier (Optional)

The audio amplifier circuit is designed to take the low-level audio signal output from the audio decoder and amplify the power so that the signal is strong enough to power the speaker. If the audio amplifier is not working, the speaker may have low or inaudible output.

A simple functional test for an audio amplifier is this: Does the amplifier take a small input signal and produce an output signal that can drive the speaker? More specific tests that can help characterize the performance of an amplifier are available but are beyond the scope of this document.

## Required Hardware:

- Audio analyzer or oscilloscope like the Rigol DS1054Z
- Function or arbitrary waveform generator like the Rigol DG1022

### Improving Test Steps:

1. Study the schematics for the design. Clearly identify high voltages and ensure adequate shielding from any high voltage areas. Disconnect the audio input and output wires from the audio amplifier.
2. Connect the function generator to the amplifier audio inputs and set the generator to an audio tone (1kHz for example) at a low voltage (10mVp-p or so)
3. Connect the oscilloscope to the amplifier outputs. A speaker can also be used in place of the oscilloscope, to hear the results rather than see them.
4. Power on the amplifier and turn on the generator and scope.
5. Configure the generator to output a sine wave at 2kHz or so. The audio range of human hearing lies from 20Hz to 20kHz, so 2kHz offers a nice starting point.
6. Enable the output on the generator and observe the output on the oscilloscope. Start with a small voltage output on the generator (10mV or less) and compare this to the output of the amplifier as shown on the oscilloscope.

The output frequency measured by the scope should match the input frequency from the generator and the output amplitude should be higher.

Adjust the frequency and amplitude of the generator and observe the output on the scope. If the output signal shows excessive distortion, incorrect frequencies, or excessive noise, it may require repair or replacement.

### Detector/Demodulator

The detector removes the carrier RF frequency (the channel to which the transmitter is tune) and passes the data (or audio) through to the next stage.



The simplest test to perform on the detector/demodulator is to input a signal at the receiver IF frequency (determined by the type of receiver and the specific design) that includes the modulation type for the receiver type. For an AM receiver, add AM modulated audio. For FM add FM modulated audio. For data, add the specific data modulation type to the RF carrier.

In any case, the idea is the same. Deliver a known test signal to the detector and monitor the output.

### Required Hardware:

- A signal source capable of creating the modulated signal (AM, FM, or data type that matches the receiver type) at the IF frequency of the receiver. This could be a single instrument or it could be combination of a standalone frequency or pattern generator coupled with an RF source (**Figure 6-3**). Many RF sources have external modulation inputs that can accept a modulated input signal and will mix it with an RF output.



Figure 6-3: A Rigol DG1022 arbitrary waveform generator and a Rigol DSG815 RF Source.

- Oscilloscope (optional). Visually verify the output of the detector stage using an oscilloscope if there is no audio capability with the receiver. The oscilloscope can also be used to check the data output visually if the receiver is designed for data transmission as well.

**Test Steps:**

1. Study the schematics for the design. Clearly identify high voltages and ensure adequate shielding from any high voltage areas.

2. Configure the RF source to output the proper IF signal; this includes the modulated and carrier portions of the signal.
3. Connect the RF source to the detector input and set it to an appropriate power level for the input to the detector.
4. Enable the power to the detector and output for the RF source. The output signal can be monitored using the speaker (if applicable) by using an oscilloscope to verify the amplitude and waveform output from the detector visually.

### Selection and IF Stages

The intermediate frequency (IF) and selection stages are responsible for filtering the desired signal from the unwanted signals brought in by the receiving antenna, separating (or demodulating) the data (audio, data, or a combination) from the RF carrier, and presenting the data to the next stage for further processing. This stage is outlined in orange in **Figure 6-4**.

Not all receivers have this specific design. Some designs incorporate other hardware or integrate the individual components shown in one package.

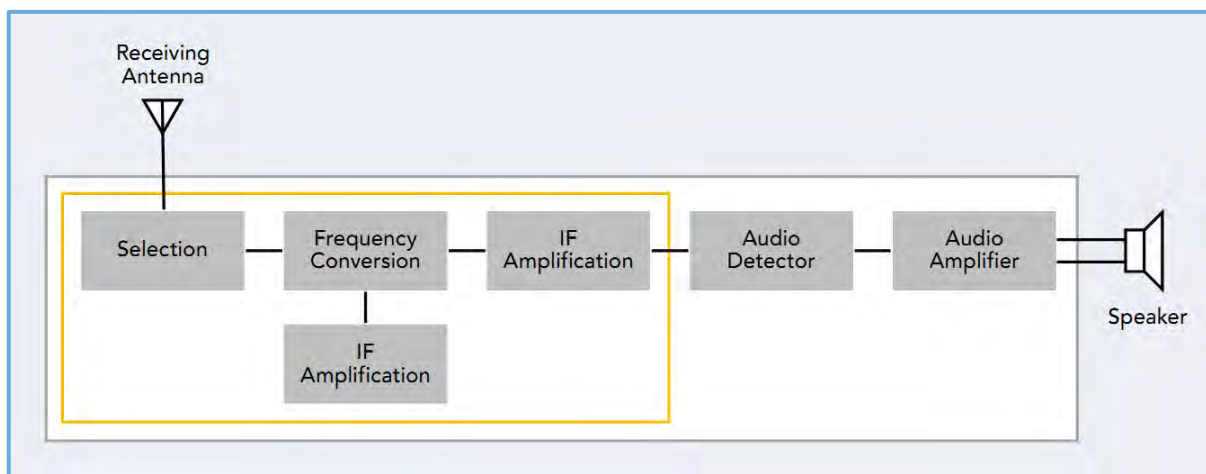

**Figure 6-4: Receiver with Selection and IF sections outlined in orange**

## IF Amplification

The input signal amplitude can be decreased significantly in the IF section. To make demodulation more successful, there can also be an IF amplification stage.

Testing the IF amplifier is simply a matter of sourcing a known modulated signal and carrier into the amplifier and measuring the output.

### Required Hardware:

- A signal source capable of creating the modulated signal (AM, FM, or data type that matches the receiver type) at the IF frequency of the receiver. This could be a single instrument or it could be the combination of a standalone frequency or pattern generator coupled with an RF source. Many RF sources have external modulation inputs that can accept a modulated input signal and will mix it with an RF output.
- Spectrum analyzer, oscilloscope, or the previously tested portions of the receiver (Audio detector, Amplifier, and Speaker) to monitor the true audio output, if the rest of the system has tested to be functioning properly.

### Test Steps:

1. Study the schematics for the design. Clearly identify high voltages and ensure adequate shielding from any high voltage areas.
2. Configure the RF source to output the proper IF signal; this includes the modulated and carrier portions of the signal.
3. Connect the RF source to the detector input and set it to an appropriate power level for the input to the amplifier.

**NOTE:** Input IF signals to the amplifier are typically very small (-100dBm). If the RF source being used is not capable of output amplitude values that are low enough, add external attenuation. External

attenuation is also useful to help protect the spectrum analyzer input if the amplifier output is expected to be high enough to damage the input of the spectrum analyzer.

4. Enable the power to the amplifier and output for the RF source. The output signal can be monitored using a spectrum analyzer or use an oscilloscope to verify the amplitude and waveform output from the amplifier visually.

## Local Oscillator (LO)

The local oscillator, commonly referred to as the LO, provides a common frequency for the intermediate frequency (IF) stage. The LO should be stable over wide environmental shifts in temperature as well as time. An unstable LO can cause the receiver to tune incorrectly or not function.

Testing the LO is as simple as monitoring the output frequency using a spectrum analyzer, oscilloscope, or frequency counter.

## Required Hardware:

- Spectrum analyzer or oscilloscope

## Test Steps:

1. Study the schematics for the design. Clearly identify high voltages and ensure adequate shielding from any high voltage areas.
2. Connect the output of the LO to the input of the spectrum analyzer.
3. Configure the analyzer center frequency to correspond to the expected output frequency of the LO.
4. Apply power to the LO and check the output frequency and amplitude on the analyzer. Compare these values to the specifications for the LO being tested.



If the analyzer is capable of performing a Max Hold trace, enable it and monitor the LO over a period of time. Max Hold traces provide a histogram of the input over successive scans. This effectively holds maximum amplitude encountered at each frequency step and can allow identifying drifting LO values. **Figure 6-5** shows the drift of an LO over time captured using a Max Hold (purple) trace over a period of time. Note that the frequency of this oscillator has drifted across a range of frequencies.

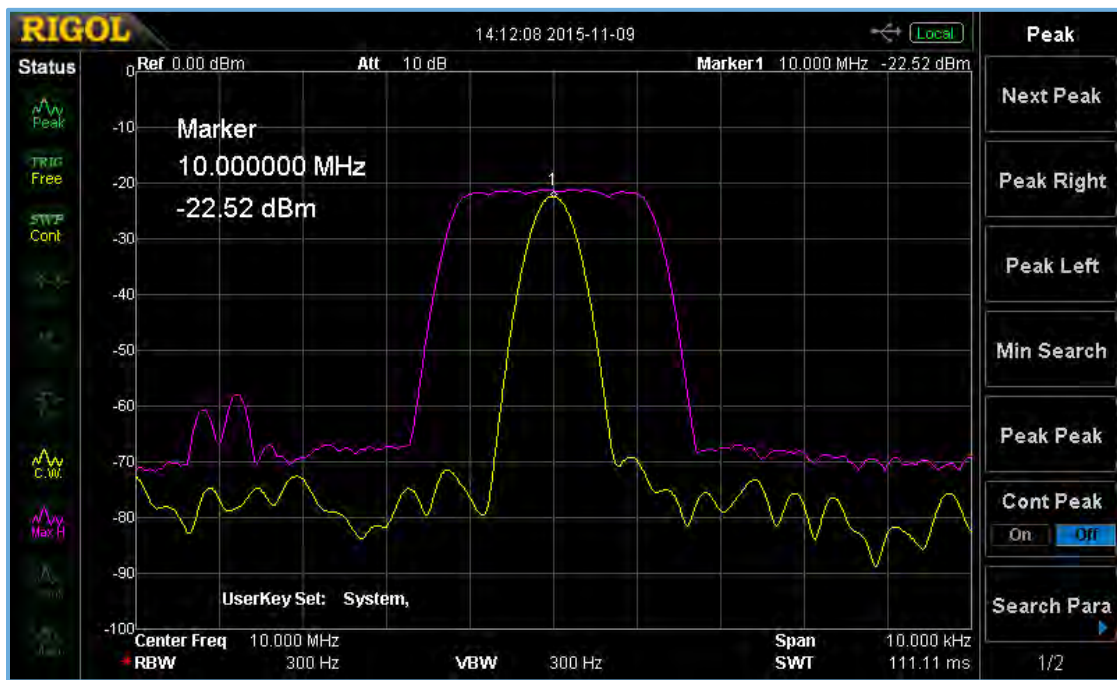

**Figure 6-5: 10MHz LO output on a spectrum analyzer. The yellow trace is a Clear Write trace type. The purple trace is a Max Hold trace type showing the drift of the LO over time.**

If the LO is not working properly, a function generator set to the LO frequency can be used as a temporary replacement for the nonfunctional LO stage. This will allow troubleshooting the remaining portions of the receiver.

### Frequency Conversion/Mixer

The main function of the frequency conversion stage is to mix the input signal (RF and modulated signal) with the LO and convert it to the intermediate frequency (IF) and filter out unwanted mixing products. This is similar to the Mixer and IF stage of the swept superheterodyne spectrum analyzer discussed in chapter 3.

In this test, an RF source with modulation capabilities (or a separate function generator acting as the modulation input) is used to deliver an RF signal with modulation to the input of the IF section. A spectrum analyzer (or the previously tested receiver sections, if functional) is used to check the performance of the IF stage.

### Required Hardware:

- A signal source capable of creating the modulated signal (AM, FM, or data type that matches the receiver type) at the IF frequency of the receiver. This could be a single instrument or it could be the combination of a standalone frequency or pattern generator coupled with an RF source. Many RF sources have external modulation inputs that can accept a modulated input signal and will mix it with an RF output.
- Spectrum analyzer

### Improving Test Steps:

1. Study the schematics for the design. Clearly identify high voltages and ensure adequate shielding from any high voltage areas.
2. Configure the RF source to output the proper RF signal; this includes the modulated and carrier portions of the signal.
3. Connect the RF source to the mixer input and set it to an appropriate power level for the input to the amplifier.

**NOTE:** The input signals at this stage typically very small (-100dBm). If the RF source being used is not capable of output amplitude values that are low enough, add external attenuation. External attenuation can also help protect the spectrum analyzer input if the amplifier output is expected to be high enough to damage the input of the spectrum analyzer.

4. Enable the power to the amplifier and output for the RF source. Monitor the output signal using a spectrum analyzer or use an oscilloscope to verify the amplitude and waveform output from the amplifier visually.

If access to the mixer/frequency conversion section is available, a spectrum analyzer with a tracking generator can be used to test the filter performance, as outlined in the *Testing Filters* section of chapter 4.

### Selection/RF Stage

The selection portion of a receiver is a tunable filter designed to accept a defined frequency and reject others outside of the selected band. A properly operating selection stage should allow the selected frequency through and reject out-of-band signals.

### Required Hardware:

- Spectrum analyzer with a tracking generator.

### Test Steps:

1. Study the schematics for the design. Clearly identify high voltages and ensure adequate shielding from any high voltage areas.
2. Configure the tracking generator of the spectrum analyzer to output an amplitude appropriate for the input to the selection stage.
3. Connect the tracking generator output to the selection stage input.
4. Configure the spectrum analyzer to scan a frequency range that is appropriate to the selection filter setting and bandwidth.
5. Connect the output of the selection stage to the tracking generator.

6. Enable the tracking generator output and observe the output of the selection stage on the spectrum analyzer display.

The output of the selection stage should effectively filter any out-of-band frequencies and pass in-band frequencies. It's recommended to test other frequency settings on the selection stage by changing the tuner on the receiver to different channels. Remember to change the analyzer frequency scan range as well to coincide with these new settings.

### Antennas, Cabling, and Adapters

The antenna is designed to collect RF signals and deliver them through the cable to the receiver. Antennas come in many shapes, sizes, and materials. They can be general purpose, like the old "rabbit ears" antennas used with broadcast television or they can be ruggedized and designed to be wavelength or directionally specific. Regardless of their design, antennas are built to transmit or receive electromagnetic radiation.

A visual inspection of the antenna, the physical mounting hardware, and all cables and connectors can go a long way towards identifying problem areas with the receiver. Antennas and cables that are outdoors are subject to wide temperature swings and constantly changing environmental conditions. Corrosion and weathering can lead to high impedances, open/broken connections, and a host of other issues.

Additional information can be found in the section on VSWR testing as covered in the components section of chapter 4.

*Thanks to Jeff Covelli (WA8SAJ) for his assistance on this chapter.*

## Chapter 8: EMI

Much of the previous discussion on RF signals has been about creating or receiving some sort of electromagnetic signal intentionally. Radios, WiFi receivers, Bluetooth devices, and mobile phones are all examples of devices that are intended to emit or receive RF signals. A host of other devices create RF signals as a side effect, based on their design. The processor and internal digital circuits on a smart phone or tablet are perfect examples of this.

Many processors and digital communications buses are rated by their clock speed. Faster clocks generally indicate faster performance. Many processors feature clocks in the 4–6GHz range, and many chip-to-chip communications on the circuit board are into the hundreds of megahertz. Signals in these frequency ranges can interfere with intentional transmissions in these frequency bands and can also cause other devices to behave erratically. These effects aren't localized to processors and digital buses. Any circuit element that exhibits sharp rise times, square pulse edges, or transient signals can emit radiation that can interfere with other devices.

To minimize the side effects, a few standard measurements can be performed on a design. This chapter introduces test methodologies and some fundamental first steps that can help one gain a better understanding of some common electromagnetic interference (EMI) tests.

### Compliance vs. Pre-Compliance

Almost any electronic design slated for commercial use is subject to EMC (electromagnetic compatibility) testing. Any company intending to sell a product must ensure that it is tested to the specifications set forth by the regulatory body of the country in which it will be sold. In the United States, the Federal Communications Commission (FCC) specifies rules on EMC testing using guidelines and test plans developed by the International Special Committee on Radio Interference (CISPR) and the International Electrotechnical Commission (IEC).



To be sold legally, a sample of the electronic product must pass a series of specific tests. In many cases, companies can self-test and certify that the product meets the standard limits, but they must have detailed reports of the test conditions and data. Many companies choose to have these tests performed by accredited compliance company. Testing that meets all of the details outlined in the test specifications for the device is referred to as compliance testing.

Fully compliant tests follow the guidelines and setup exactly and the results can be used to certify the device for compliance to the test procedures. However, this type of testing can be expensive and may require specialized test environments and equipment that might be beyond the reach of many companies.

One method to lower the additional costs associated with ensuring EMC compliance is to perform EMC testing throughout the design process, well before sending the product off for full compliance testing. This pre-compliance testing can be very cost-effective and can be tailored to match the conditions used for compliance testing closely. This will increase the company's confidence in passing compliance the first time, lower test costs, and speed time to market.

The following sections introduce pre-compliance test methods that can be used to troubleshoot a design's potential EMI-related issues. Although the simple tools and test methods described can ease the reader into the world of EMI/EMC testing, there is much more that can be learned independently about full compliance testing. Of the many texts available for independent study, we recommend Henry Otts's *Electromagnetic Compatibility*, as well as *EMI Troubleshooting Cookbook for Product Designers* by André and Wyatt.

## Measuring Radiated EMI/Near-Field

An unintentional radiator is a device that transmits RF as a byproduct or side effect of its intended operation. In simple terms, an unintentional radiator is much like a radio transmitting noise across multiple stations at one time. These radiated transmissions can have an adverse effect on other devices that receive this undesired signal.

One common test is to measure the radiated emission of a product by placing a spectrum analyzer and an antenna a few meters away from it. This is called a far-field radiated emissions test (**Figure 7-1**).

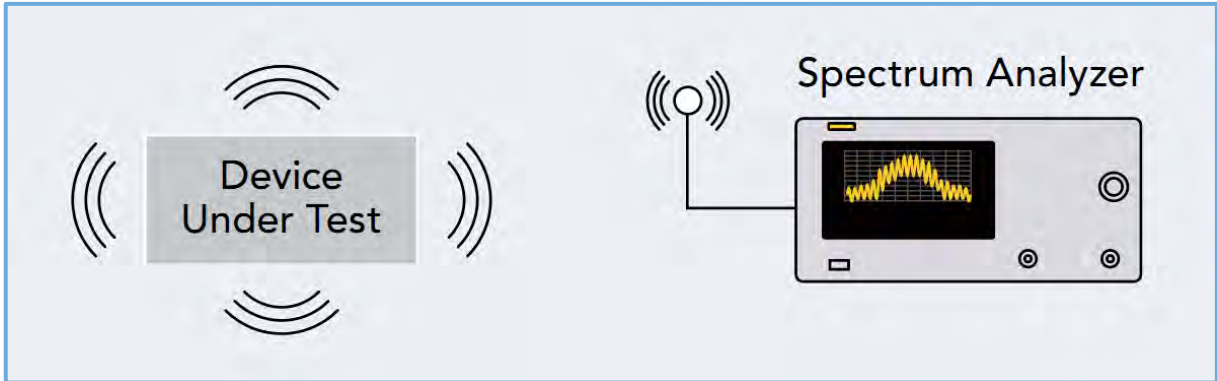

Figure 7-1: Simple block diagram of a radiated emissions test.

In this test, an antenna is attached to a spectrum analyzer and measurements are performed over a frequency span of interest. Although the idea sounds simple, this test method has some major problems:

- Most antennas are broadband. That is, they accept a wide range of frequencies and do not differentiate between those outside of the test area and the actual test device. This makes any measurements performed using an antenna very susceptible to other RF signals like radio stations, WiFi, etc.
- Other environmental factors (metal shelving, desks, people, etc.) can also adversely affect the measurements. This can be due to reflections and absorption of the signals by the environment and can make repeatable and accurate measurements nearly impossible.

Successfully executing fully compliant radiated emissions tests involve a similar setup, but they also require the use of test areas with very low external RF sources that could interfere with the measurement. Open Air Test Sites (OATS) are basically open test areas in geographic locations that feature minimal RF signals... such as an open prairie in the middle of North Dakota, for example.

OATS facilities were very popular in the twentieth century, but their numbers have dwindled due to the exponential increase in external RF sources. At that time, most RF was produced by AM and FM radio, and open air facilities could be placed in areas without much RF interference. Now, with WiFi, mobile phones, and Bluetooth devices, RF signals are everywhere.

A more useful solution comes in the form of special test chambers that attenuate external RF signals and minimize internal RF reflections. These anechoic and semi-anechoic chambers provide this function but can be

very expensive. A small semi-anechoic chamber a few feet wide by a few feet tall can cost \$50,000 or more, which in most cases is too costly for infrequent test needs.

Near-field probing is a test technique that uses special probes that minimize the effects of stray environmental RF. Near-field probes typically have two designs. Magnetic-field, or H-field, probes feature loops that help couple the magnetic fields produced by time-varying currents. Both designs are very sensitive to distance from the source of the radiation. They need to be within a few inches of most sources to measure, even with a very sensitive analyzer or preamp attached.



Figure 7-2: Rigol NFP Near Field EMC probes.

The simplest test is to configure the DSA to use the peak detector and set the RBW and Span for the area of interest per the regulatory requirements for the device being tested. Then select the proper E or H probe for the design and scan over the surface of the design.

Probe orientation (rotation, distance) is also important to consider. The probes act as an antenna, picking up radiated emissions from seams, openings, traces, and other elements that could be emitting RF. A thorough

scan of all of the circuit elements, connectors, knobs, openings in the case, and seams is crucial. **Figure 7-4 shows using an H-field probe to test emitted radiation.**

For the first pass, configure the spectrum analyzer to use the peak detector. This will provide a “worst-case” reading on the radiated RF and it is the quickest path to determining the problem areas. Larger probes will allow a faster scanning rate, albeit with less spatial resolution.

Once problem areas are identified, a few common techniques allow getting more details on them. Whenever possible, select a spectrum analyzer that has the standard configuration used in full compliance testing. This includes a quasi-peak detector mode, EMI filter, and resolution bandwidth (RBW) settings that match the full test requirements specified for the product.

This type of setup will increase testing time but should be used on the problem areas. A full compliance test utilizes these settings, so pre-compliance testing with this configuration will provide a greater degree of visibility into the EMI profile of a design.

Many instruments also support storing cable and antenna correction factors that will make it possible to see the true signal, without the added errors from the setup.

The next step in radiated testing includes using antennas in place of the near-field probes and a rotating platform for the equipment under test (EUT). It can also include a special room that minimizes environmental factors (semi-anechoic). These setups are beyond the scope of this document, but references at the end of this chapter provide good references for the details of that setup.

### Near-Field Probing Setup

Board-level emission testing can be performed using a spectrum analyzer, like the Rigol DSA-815 (9kHz to 1.5GHz), near-field electric (E) and magnetic (H) probes, and the appropriate connecting cable.



Figure 7-3: The Rigol DSA815-TG Spectrum Analyzer.

Using the near-field probes shown in **Figure 7-3** with a Rigol spectrum analyzer requires a 50Ω cable that terminates in an N-type connector (spectrum analyzer end) and SMB (probe end).

It's also possible to build probes by removing a few centimeters of outer shield and insulator from a semi-rigid RF cable, bending it into a loop, and dipping in plastic tool dip or other insulating material. Larger diameter loops will pick up smaller signals but do not have as much spatial resolution as smaller diameter loops.

For the first pass, configure the spectrum analyzer to use the peak detector. This setting ensures that the instrument is capturing the “worst-case” peak RF. It also provides a fast scan rate to minimize the time spent at one position when scanning over the DUT. Larger probes will allow for a faster scanning rate, albeit with less spatial resolution. Smaller probes, like the E-field probe, provide fine spatial resolution and can be used to detect RF on single pins of circuit elements.

Probe orientation (rotation, distance) is also important to consider. The probes act as an antenna, picking up radiated emissions. Exposing the loop to the largest perpendicular field possible will maximize the signal strength.



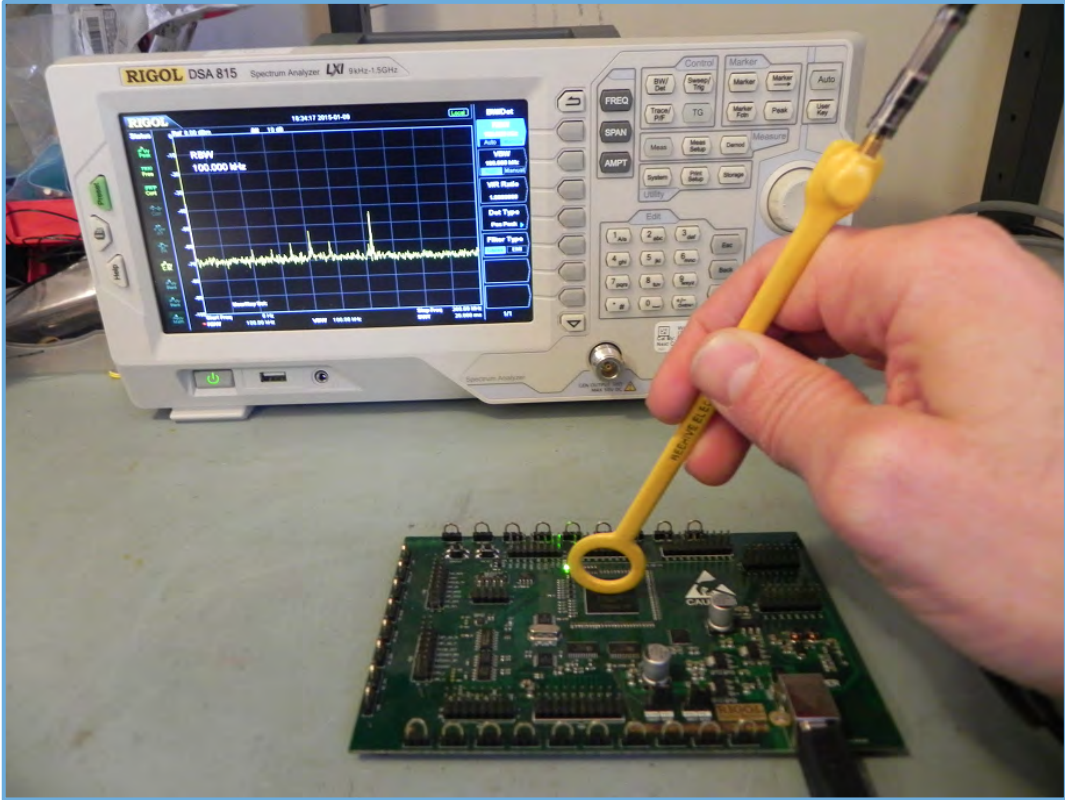

**Figure 7-4: An example of using an H-field probe and spectrum analyzer to find trouble spots on a board. Note the orientation of the H-field probe**

Take care to test enclosure seams, openings, traces, and other elements that could be emitting RF signals. A thorough scan of all of the circuit elements, connectors, knobs, openings in the case, and seams is crucial to identifying potential areas where RF can “leak” out of an enclosure.

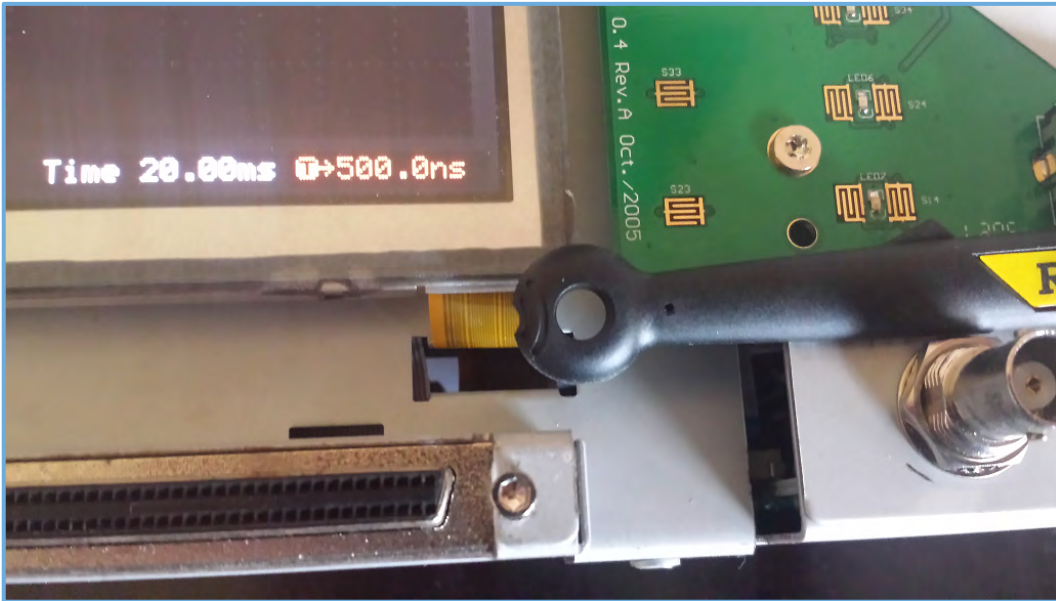

**Figure 7-5: Measuring a display ribbon cable for emissions using an H-field probe.**

Use tinfoil or conductive tape to cover suspected problem areas like vents, covers, doors, seams, and cables coming through an enclosure. Simply test the area without the foil or tape, then cover the suspected area, and rescan with the probe.

Once problem areas have been identified, implementing a few common techniques can provide additional detail. If possible, select a spectrum analyzer that has the standard configuration used in full compliance testing. This includes a quasi-peak detector mode, EMI filter, and resolution bandwidth (RBW) settings that match the full test requirements specified for the product.

This type of setup will increase testing time but should be used on the problem areas. A full compliance test utilizes these settings, so pre-compliance testing with this configuration will provide a greater degree of visibility into the EMI profile of a design.

### Tips

Near-field probes and a spectrum analyzer can be useful tools in troubleshooting EMI issues.

- With H-field probes, try different probe orientations to help isolate problem areas.

- Remember to probe all of the seams, openings, and cutouts around the enclosure of the device. Surface contact between mating parts, as well as the finish of the materials, can adversely affect the grounding and shielding properties of an enclosure.
- Openings radiate just like solid structures. They act like antennas.
- Ribbon cables and cables/inputs with bad shielding and grounds are common causes of radiated emissions.

## Measuring Conducted EMI

Conducted EMI testing requires analyzing the RF energy that is coupled from the instrument or test circuit to the main power line to which it is connected. RF signals traveling down the power line can cause interference in the AM radio transmission bands. In order to minimize this interference, it is important to quantify the RF power and frequencies that a product produces when plugged into the power grid.

Like radiated EMI, conducted EMI is measured using a spectrum analyzer, but it also requires a transient limiter and a Linear Impedance Stabilization Network (LISN). An LISN isolates the power mains from the equipment under test, isolates any noise generated by the EUT, and couples the signals generated by the EUT to the spectrum analyzer.

As with emissions testing, the best start is a scan over the frequency range of interest using the peak detector on the spectrum analyzer. If any peaks are within 3dB or so of the limit line, make note of their frequencies. Then, perform a quasi-peak scan over a 1MHz span centered around each peak. This will save you measurement time and provide a more accurate representation of the true amplitude of the RF power of the EMI.

## Conducted Emission Measurement Setup

The more closely this setup matches a full compliance setup, the more closely the data acquired will match with the lab. However, this isn't always practical.

**Figures 7-6** and **7-7** show the standard suggested electrical and physical setups for testing conducted

emissions:

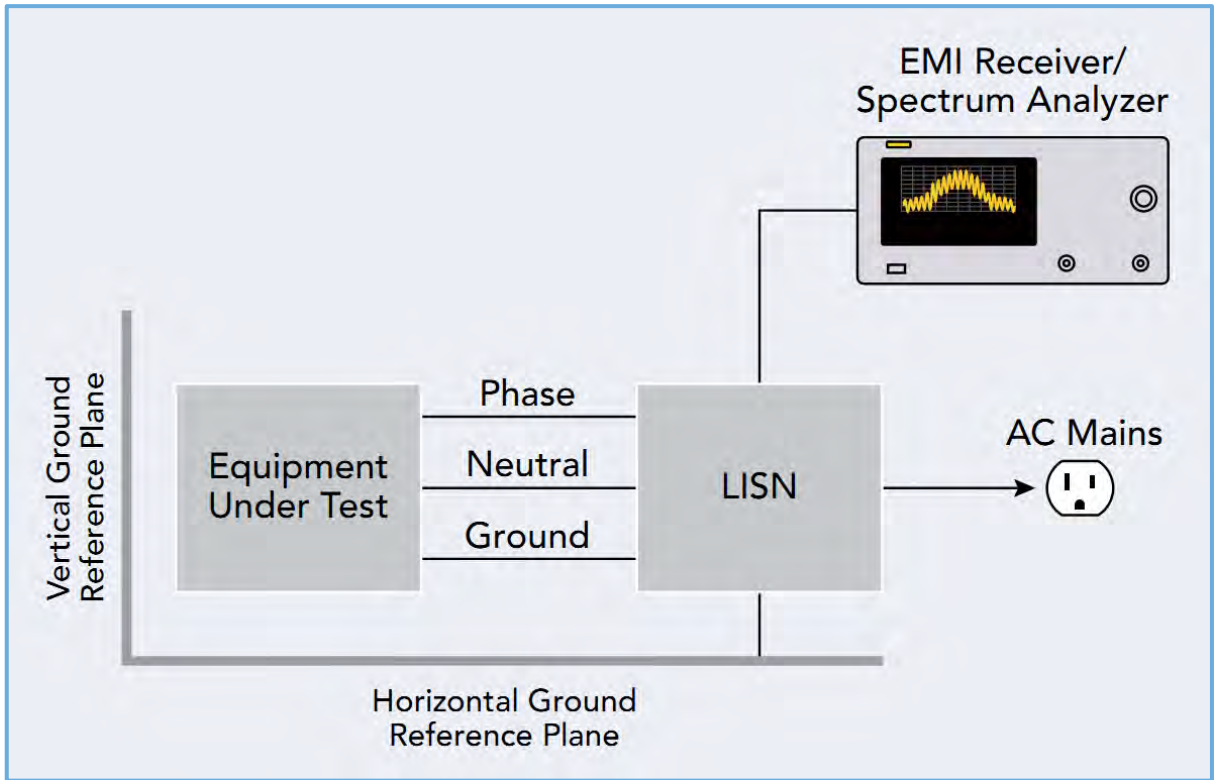

Figure 7-6: Electrical connections for conducted EMC testing.

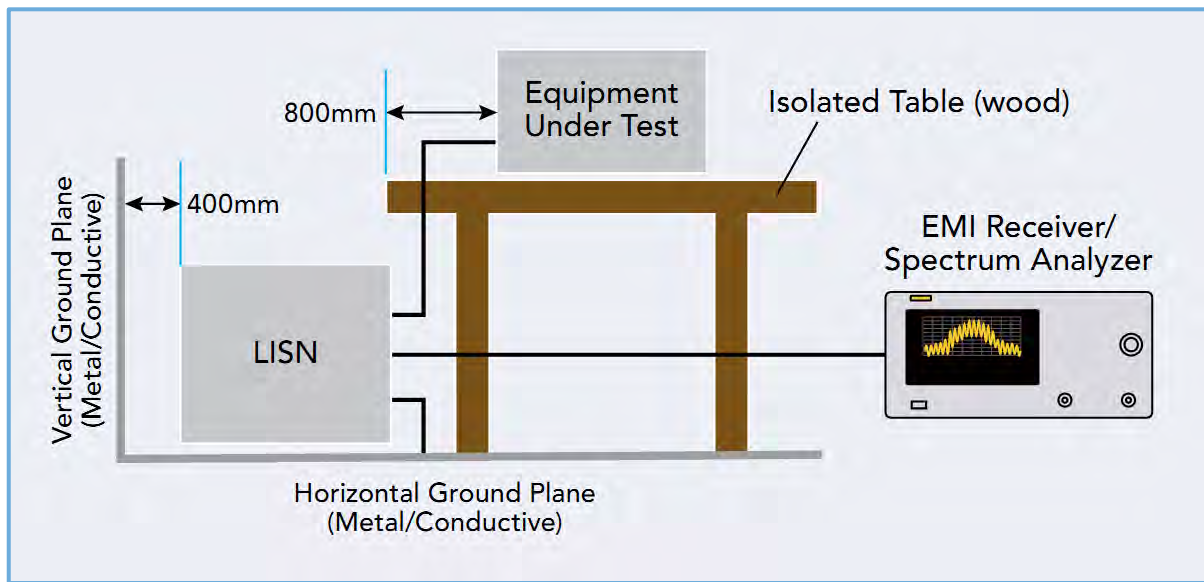

Figure 7-7: Physical connections for conducted EMC testing.

Here are the key points to remember:

6. The horizontal and vertical ground planes are typically sheets of metal with surface areas twice the dimensions of the equipment-under-test.
7. The horizontal and vertical ground planes should be electrically bonded to each other.
8. Equipment should be placed on an insulated table over the horizontal ground plane. No equipment or cabling should run below the equipment.
9. The LISN should be electrically bonded to the horizontal ground plane. The LISN's job is to separate the AC Mains noise from the conducted noise being generated by the equipment-under-test. Select a LISN that has the proper voltage, current, and frequency ranges for the equipment-under-test.
10. Do not coil cables; minimize inductive loops by laying cabling out smoothly.
11. The spectrum analyzer should be placed some distance away from the horizontal ground plane, typically a few feet away.

## Test Procedure

Once the EUT is set up and bonded the LISN and ground planes, power on the spectrum analyzer for at least 30 minutes to ensure stability and accuracy.

## Configure Spectrum Analyzer

- Option: If the analyzer has settings for enabling quasi-peak detection as well as the FCC resolution bandwidths of 200Hz, 9kHz, and 120kHz, they can be used to obtain data that could more accurately represent data collected during true compliance tests. Be aware that quasi-peak detectors can take a much longer time for scan completion.
- Set resolution bandwidth.

**NOTE:** The resolution bandwidth is determined by the standard and specific device type under test. As an example, FCC subpart-15 specifies an RBW of 9kHz when testing from 150kHz to 30MHz.

- Consult the standards to which the product or circuit is being tested to for more information on the specifications governing the testing process.



**NOTE:** Many specifications give limits and values in dB $\mu$ V or V.

- Optional: Set scale for volts if the analyzer has that capability.

**NOTE:** Some analyzers have pass/fail features that allow configuring an upper limit line. This can be useful when evaluating the frequency scan with respect to the limits set forth by the EMC standard to which testing is being performed.

- Any limit lines can be saved to the internal storage.
- Set detector type to Positive Peak. The positive peak detector will show the highest value and provide the “worst-case” value for pre-compliance scans.
- Adding an external transient limiter and 10dB to 20dB of external attenuation is recommended to minimize the likelihood of damage to the sensitive front end of the spectrum analyzer. The attenuator protects the input circuit from any unknown signals that could damage the input. It also serves as a convenient check on overloading after checking the background readings.
- The DSA has protection circuitry, but there are transients that are too fast to protect against.
- Set frequency start, stop values set forth in the EMC Specifications that apply to the product.
- Set the resolution bandwidth (RBW) to the value set forth in the EMC Specifications that apply

## Improving Signal Fidelity Check Background Readings

- Power up LISN.
- Connect the spectrum analyzer to the LISN output.
- Scan over the frequency band of interest using the detector set to “peak” and with the attenuator set to 10dB.

## Peak Test

- Disconnect the spectrum analyzer from the LISN.
- Connect the equipment-under-test (EUT) to the LISN.
- Reconnect the spectrum analyzer to the LISN. This process helps to minimize damage to the spectrum analyzer due to transients on the input.
- Observe the conducted emissions scan and adjust the attenuation value to 20dB. If the line does not change for different attenuation values, then it is likely that the input is not being overloaded the input and the measurement quality is high, so it’s safe to proceed with the pre-compliance testing.

If the scan changes value with different attenuation settings, then it is likely that the input is being overloaded with broadband power and additional attenuation is recommended. Try comparing scans of 20dB and 30dB, etc. until a range without variation is found. The objective is to select the smallest attenuation value that does not show errors due to the overloading effects of the input signal. In the worst case, the EUT may not be able to be tested successfully with a spectrum analyzer, so a true EMI receiver with pre-selection filters might be needed.

- Observe conducted emissions and look for frequency lines that are above the limit line previously set. Make note of the frequencies failing the limit lines.

### Quasi-Peak Scans

- Using the failed frequencies noted previously, adjust the spectrum analyzer to center the failed peak.
- Note the RBW setting for the scan, and make the frequency span twice the RBW setting used for the peak scan. For example, if there is an over limit peak at 10MHz, and an RBW of 120kHz, center the quasi-peak scan at 10MHz, and scan from 9.88MHz to 10.12MHz. Optional: Change the detector type to quasi-peak.

**NOTE:** The quasi-peak detector is based on charge and discharge times of a standardized resonant circuit. This detector type can take more than three times the scan time of a peak measurement. That is why it is best to use quasi-peak only over short spans.

- Compare the quasi-peak data to the pass/fail limit line for that frequency.
- It is advisable to keep the conducted emissions at least 10dB lower than the specified limit line. This margin of error will increase the likelihood of passing a full compliance test.
- It is also advisable to compare the pre-compliance data and setup to that of the full compliance lab that will perform the EMC certification testing. This will make it easier to identify any problems with pre-compliance testing. More comparisons make it possible to hone the pre-compliance error budget and allow more confidence in the results obtained.

## Immunity Testing

Products that contain electronics can be sensitive to radio frequency (RF) interference. Devices that experience RF interference can be prone to improper or failed operations. Products that suffer problems when exposed to RF interference are said to be susceptible to interference; products that do not exhibit issues when exposed to RF interference are said to be immune to interference.

RF interference can cause:

- Scrambled display information
- Slow, frozen, or locked operations (no response from keys, knobs)
- False or noisy data
- System reset or reboot

Design analysis, including part selection, shielding, and cable selection is the first step in creating a product that is capable of operating “as expected” under a certain degree of RF interference; however, testing early under real-world conditions is one sure way to determine if a design is susceptible to any issues with RF.

The following section illustrates how an RF generator and some simple tools can be useful in identifying weaknesses in a product design.

## Radiated Susceptibility

Radiated susceptibility tests involve observing the operation of a device-under-test (DUT) while it is being subjected to a known RF source. The signal is delivered to the DUT using antennas for far-field testing or near-field probes for board-level tests.

Most radiated susceptibility regulations are based on IEC 61000-4-3, which defines the test signals range from 80–1,000MHz. This signal can be modulated by a 1kHz AM sine wave with 80% modulation depth. The modulated signal helps to identify any rectification issues within sensitive circuit elements quickly.

In far-field tests, an RF signal source, like the Rigol DSG3000 or DSG800 series, is connected to an antenna that is set up a meter or two from the DUT. The RF source is then configured to source an output with 80% AM

modulation at 1kHz. The amplitude should be set as high as possible, and the carrier frequency can be set at 9kHz.

**NOTE:** The DUT should be configured in its most commonly used state. All cabling (power, I/O, etc.) should be connected and in place. Cables can act like antennas and can directly influence performance.

Observe the DUT for any functional changes or issues such as a glitchy or noisy display. Now, increase the carrier frequency and check the DUT. Step the center frequency of the generator and continue to observe the DUT, making note of the carrier frequencies that cause issues and the type of problems observed. After the stepping up to 1GHz is complete, rotate the DUT with respect to the antenna and re-test to provide a more thorough test.

**NOTE:** Antennas should only be used in shielded anechoic or semi-anechoic chambers to prevent interference with communications and emergency broadcast bands. It is illegal to broadcast over many frequency bands without proper licensing.

The use of an RF source like the Rigol DSG3000 or DSG800 series offers the flexibility to adjust the wavelength, power, and modulation of the output to help identify problem areas quickly.



Figure 7-8: The Rigol DSG800 and DSG3000 RF Source.

Near-field testing is helpful because it does not require specialized chambers for testing. The E- and H-field probes only produce strong fields at distances less than one inch from the tip of the probe and do not radiate efficiently enough to cause problems with broadcast and emergency systems. Their small size also allows pinpointing the RF at specific circuit elements.

A commercial example of near-field probes are the Rigol probes shown in **Figure 7-9**.





**Figure 7-9: Rigol NFP EMC probes. The loops are H-field type.**

The RF source is configured exactly as in the far-field test, but this time, the probe tip is placed very close to the circuit or elements of the board at each carrier frequency. While scanning across the circuit, observe the DUT and be sure to check for any issues, especially near sensitive analog circuitry.

**Figures 7-10 through 7-12** show what happens when the shielding is removed from an oscilloscope board and an E-field probe and a DSG3000 are used to deliver RF signals into the sensitive analog front end. Note how, with the shielding removed, the RF causes data corruption and changes the waveform significantly.



Figure 7-10: Using a near-field probe on an unshielded oscilloscope analog input circuit.

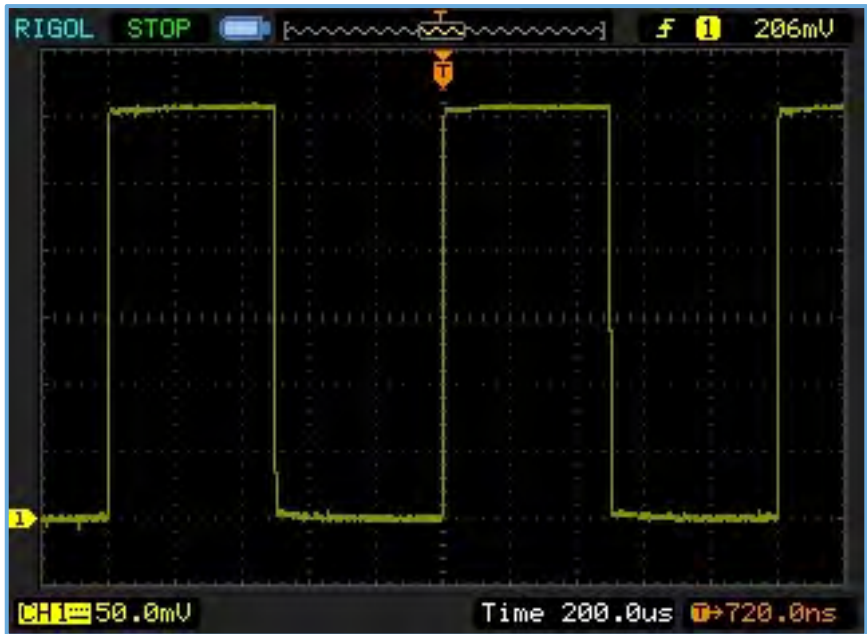

Figure 7-11: Oscilloscope data with shielding in place.

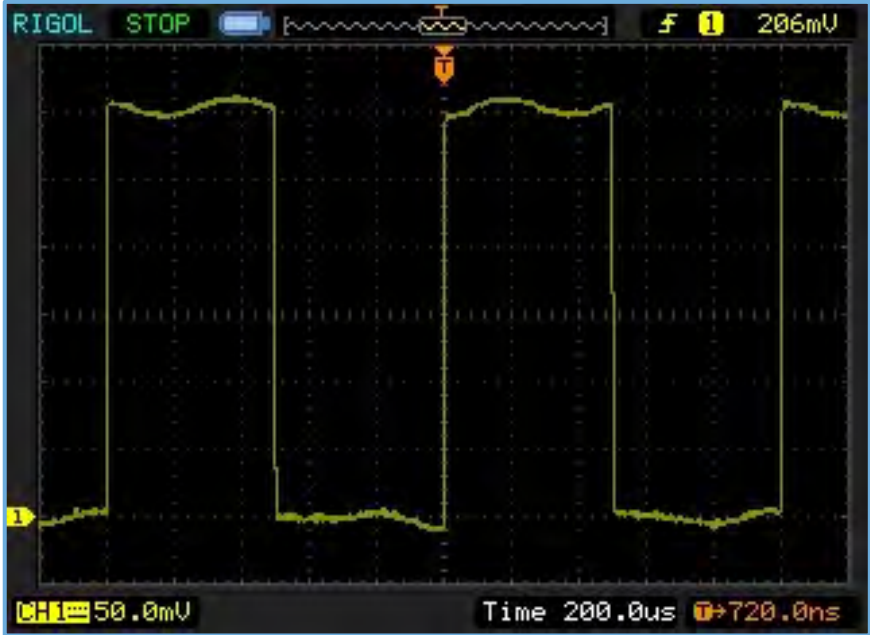

Figure 7-12: Oscilloscope data without shielding.

### Additional Testing

Another useful test technique is to use a current probe and RF source to deliver RF signals to cables connected to the DUT. Cables can act like antennas and couple undesired signals to the DUT. This setup can be used to step through different frequencies and check the susceptibility of a design. Commercial current probes can be used, but an acceptable current probe can be built using a snap-on ferrite choke, a few winds of insulated wire, some epoxy, and a BNC connector as shown in **Figure 7-13**.



Figure 7-13: Hand-made current probe.

The first step is to set up the DUT and connect all of the cables that are common to its usage. Configure the source to output maximum power with the same 80% 1kHz AM modulation that was suggested previously for far- and near-field tests and observe the DUT for problems. Step the carrier frequency and observe. Perform this test to the maximum desired frequency and repeat the process on each cable used with the DUT.

**NOTE:** Clamp probes should only be used in shielded anechoic or semi-anechoic chambers to prevent interference with communications and emergency broadcast bands. It is illegal to broadcast over many frequency bands without proper licensing.

To demonstrate the use of a current probe, an experiment was performed on a USB-powered demonstration board, using a DSG3000 and a hand-made probe clamped to a non-filtered USB cable connected to the board. The output signal was monitored.

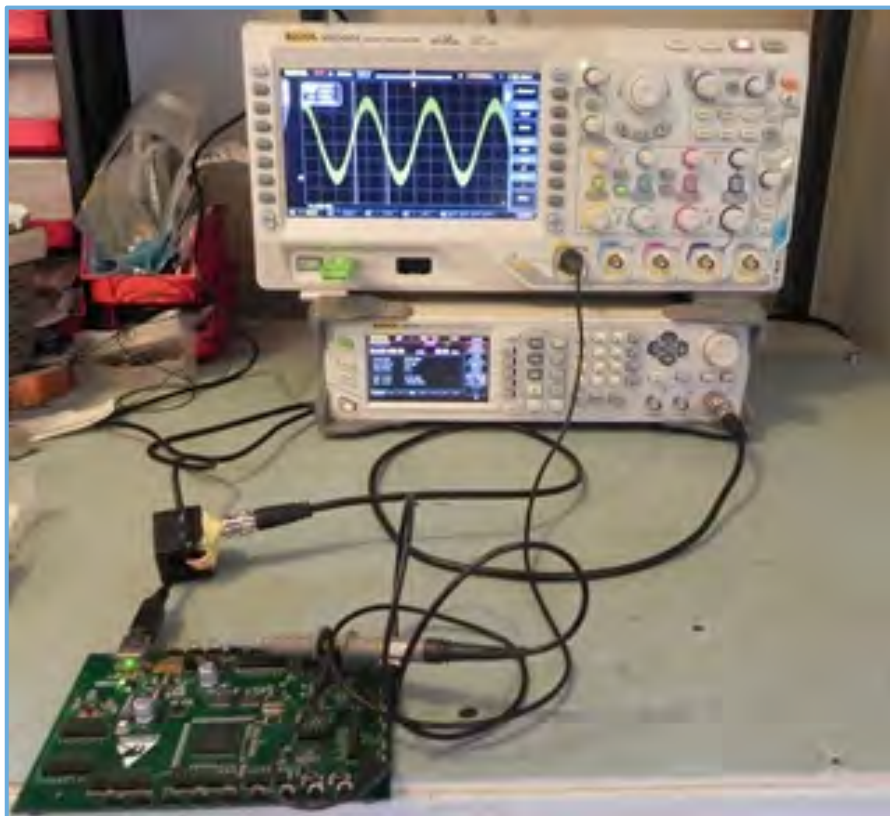

Figure 7-14: Injection of RF to an unfiltered USB cable.

With no RF applied, the data was smooth.

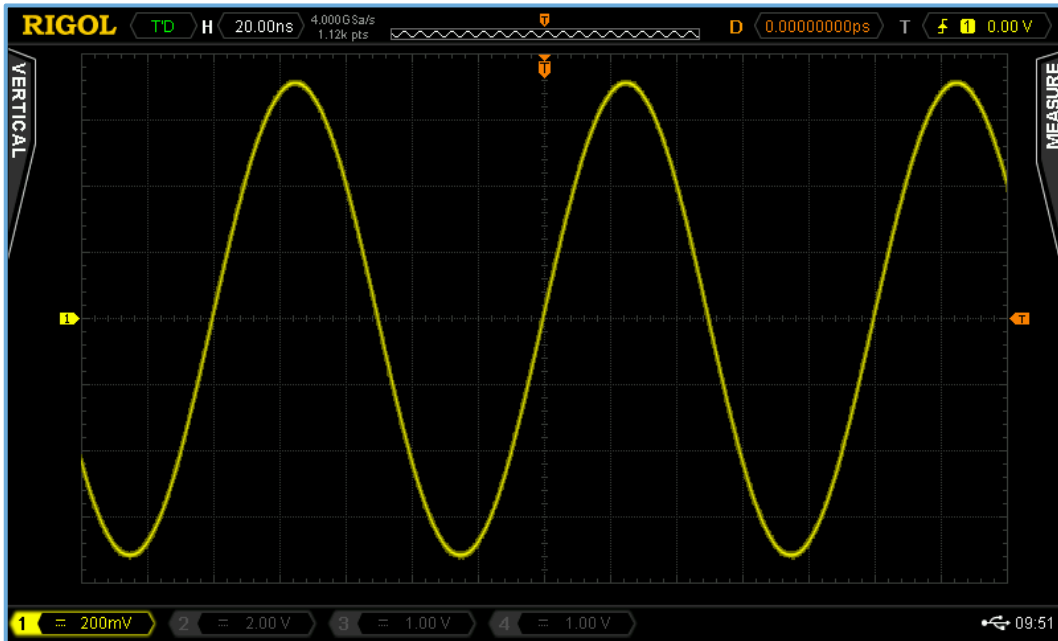

Figure 7-15: Sine wave from board without RF interference.

However, when an RF signal was applied, the output began to show signs of interference. The worst interference occurred at an RF carrier frequency of 110MHz, as shown in **Figure 7-16**.

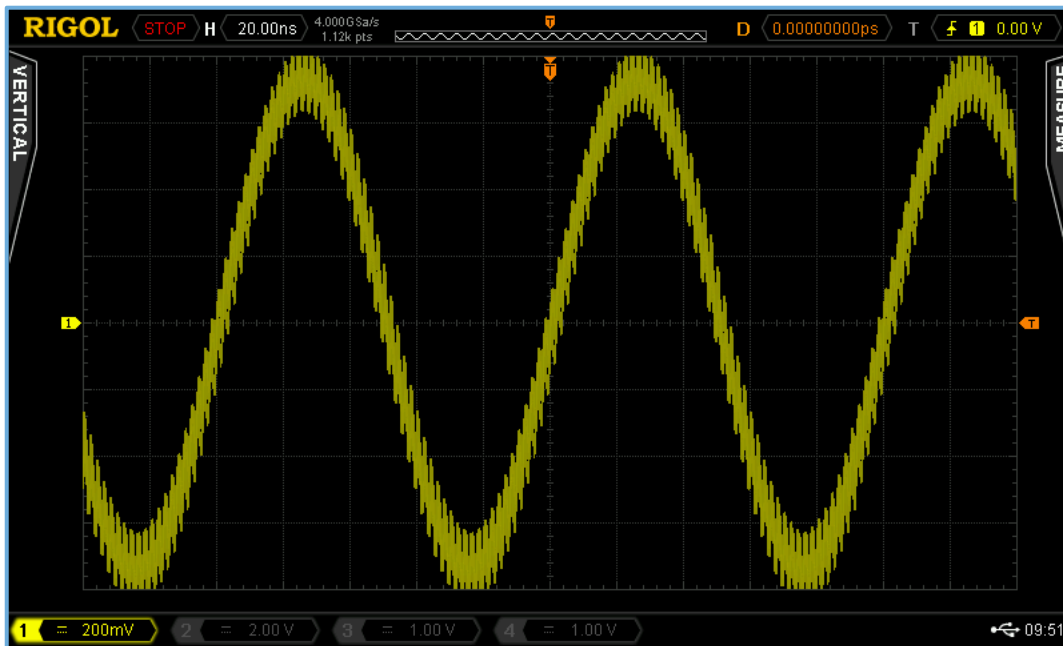

Figure 7-16: Noisy data showing RF interference at 111.1MHz due to injected noise.



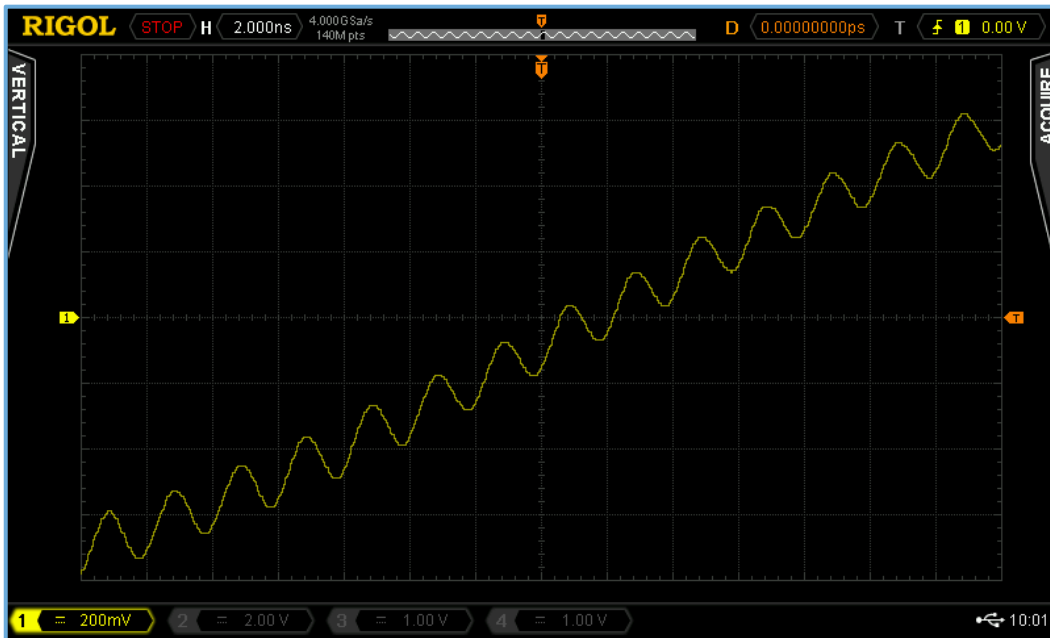

Figure 7-17: Zoomed data to show details.

In conclusion, an RF source like the Rigol DSG3000 or DSG800 and some simple tools allow testing designs for immunity issues early in the development process, saving time and money.

**RIGOL**  
Innovation or nothing

**RIGOL Technologies Inc.**

8140 SW Nimbus Ave.

Beaverton, OR 97008

877-4-RIGOL-1

info@rigol.com

www.rigolna.com